



Vestil Manufacturing Corp.

2999 North Wayne Street, P.O. Box 507, Angola, IN 46703

Telephone: (260) 665-7586 -or- Toll Free (800) 348-0868

Fax: (260) 665-1339

Web: www.vestilmfg.com e-mail: info@vestil.com

LLW, LLPW, ALLW, & ALLPW LIGHT LOAD LIFTERS

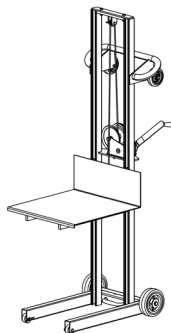

(A)LLW-FW

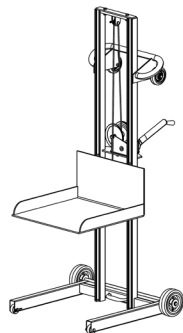

(A)LLPW-FW

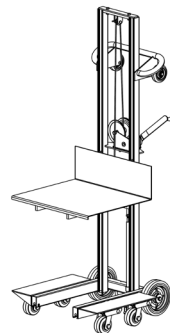

(A)LLW-4SFL

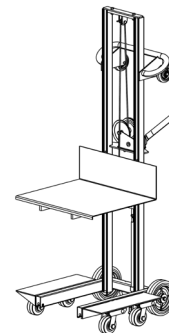

(A)LLPW-4SFL

Receiving Instructions

After delivery, remove the packaging from the product. Inspect the product closely to determine whether it sustained damage during transport. If damage is discovered, record a complete description of it on the bill of lading. If the product is undamaged, discard the packaging.

NOTE: The end-user is solely responsible for confirming that product design, use, and maintenance comply with laws, regulations, codes, and mandatory standards applied where the product is used.

Technical Service & Replacement Parts

For answers to questions not addressed in these instructions and to order replacement parts, labels, and accessories, call our Technical Service and Parts Department at (260) 665-7586. The Department can also be contacted online at http://www.vestilmfg.com/parts_info.htm.

Electronic Copies of Instruction Manuals

Additional copies of this instruction manual may be downloaded from <https://www.vestil.com/page-manuals.php>.

Table of Contents		Page
Specifications (dimensions, capacity, net weight): LLW & ALLW.....		2
Specifications (dimensions, capacity, net weight): LLPW & ALLPW.....		3
Signal Words.....		4
Safety Instructions.....		4
National Standards.....		4
LLW-202058-FW Exploded View & Bill of Materials.....		5
ALLW-2020-FW Exploded View & Bill of Materials.....		6
ALLW-2020-FWFL Exploded View & Bill of Materials.....		7
LLW-202058-FWFL Exploded View & Bill of Materials.....		8
LLW-202058-FWWL Exploded View & Bill of Materials.....		9
LLW-242060-4SFL Exploded View & Bill of Materials.....		10
ALLW-2420-4SFL Exploded View & Bill of Materials.....		11
LLPW-500-FW Exploded View & Bill of Materials.....		12
LLPW-500-FWFL Exploded View & Bill of Materials.....		13
ALLPW-500-FW Exploded View & Bill of Materials.....		14
ALLPW-500-FWFL Exploded View & Bill of Materials.....		15
LLPW-500-4SFL Exploded View & Bill of Materials.....		16
ALLPW-500-4SFL Exploded View & Bill of Materials.....		17
Raising and Lowering the Deck.....		18
Using the Hand Truck.....		18 - 19
Record of Satisfactory Condition.....		19
Inspections & Maintenance.....		20
Labeling Diagram.....		21
Limited Warranty.....		22

SPECIFICATIONS

Dimensions, net weight, and capacity information for standard models appear in the diagrams & tables.

LLW-202058-FW; ALLW-2020-FW; LLW-202058-FWFL; ALLW-2020-FWFL; & LLW-202058-FWWL

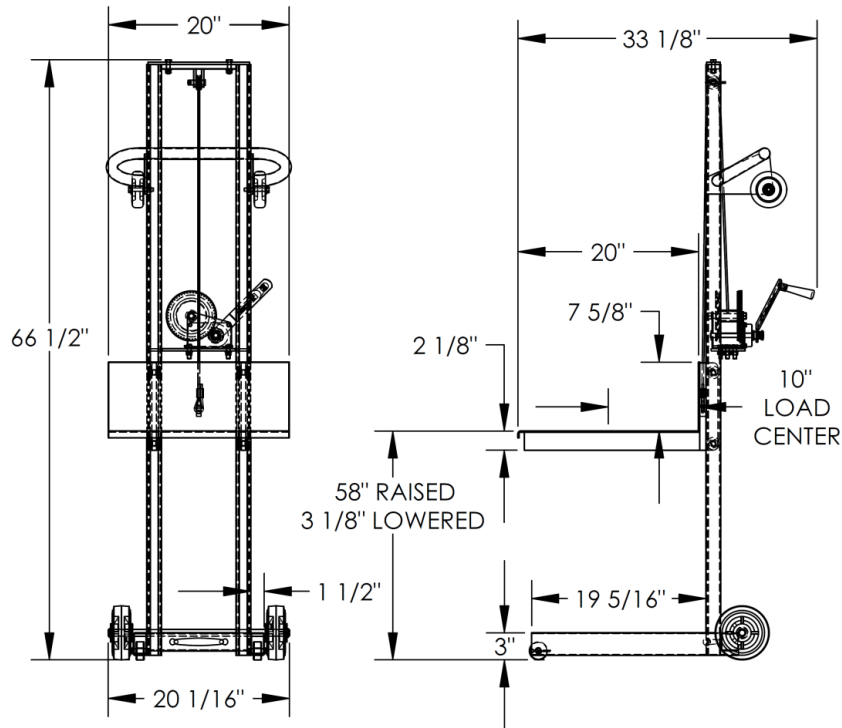

Model	Net Weight	Capacity
LLW-202058-FW	154 LB. 70 KG	400 lb. 181.8 kg
LLW-202058-FWFL	157 LB. 71.4 KG	400 lb. 181.8 kg
ALLW-2020-FW	84 LB. 38.2 KG	400 lb. 181.8 kg
LLW-202058-FWWL	156 LB. 70.9 KG	400 lb. 181.8 kg
ALLW-2020-FWFL	86 LB. 39.1 KG	400 lb. 181.8 kg

LLW-242060-4SFL & ALLW-2420-4SFL

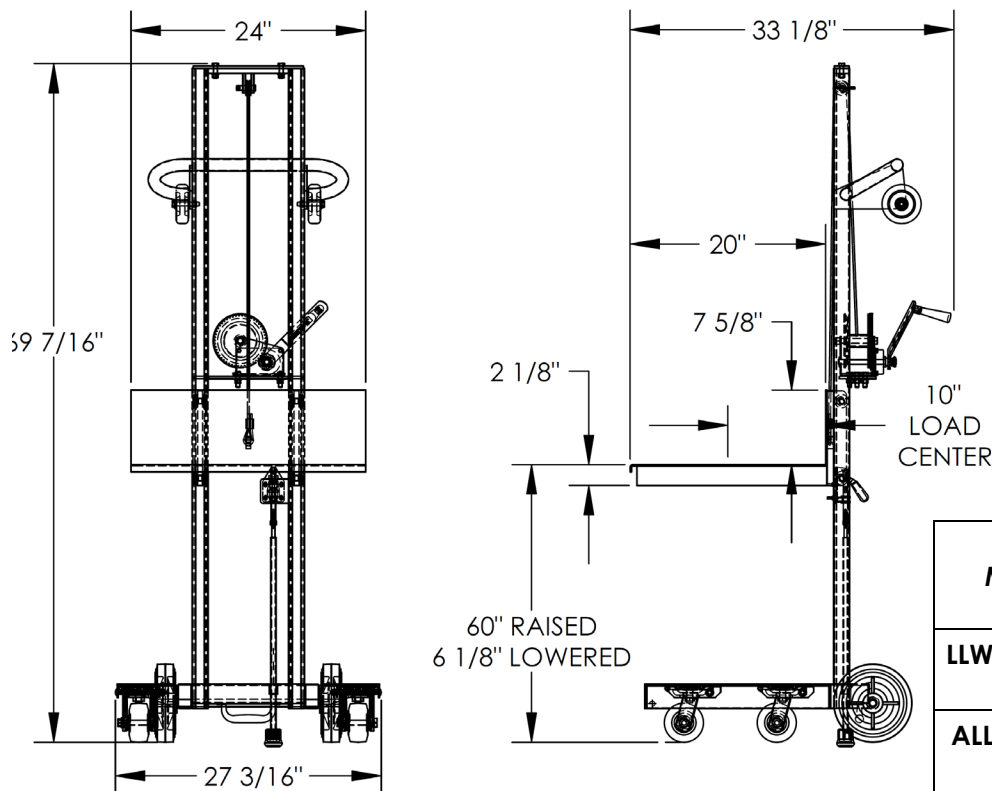

Model	Net Weight	Capacity
LLW-242060-4SFL	215 LB. 97.7 KG	400 lb. 181.8 kg
ALLW-2420-4SFL	127 LB. 57.7 KG	400 lb. 181.8 kg

LLPW-500-FW; ALLPW-500-FW; LLPW-500-FWFL & ALLPW-500-FWFL

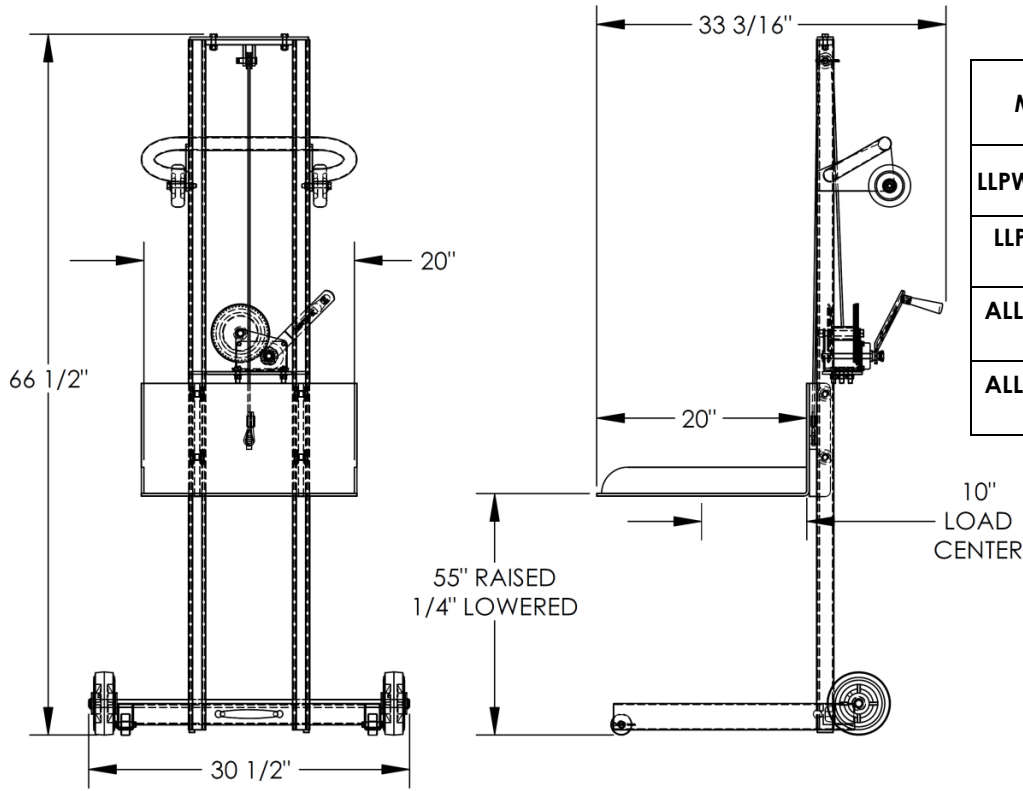

Model	Net Weight	Capacity
LLPW-500-FW	179 LB. 81.4 KG	400 LB. 181.8 KG
LLPW-500-FWFL	182 LB. 82.7 KG	400 LB. 181.8 KG
ALLPW-500-FW	92 LB. 41.8 KG	400 LB. 181.8 KG
ALLPW-500-FWFL	94 LB. 42.7 KG	400 LB. 181.8 KG

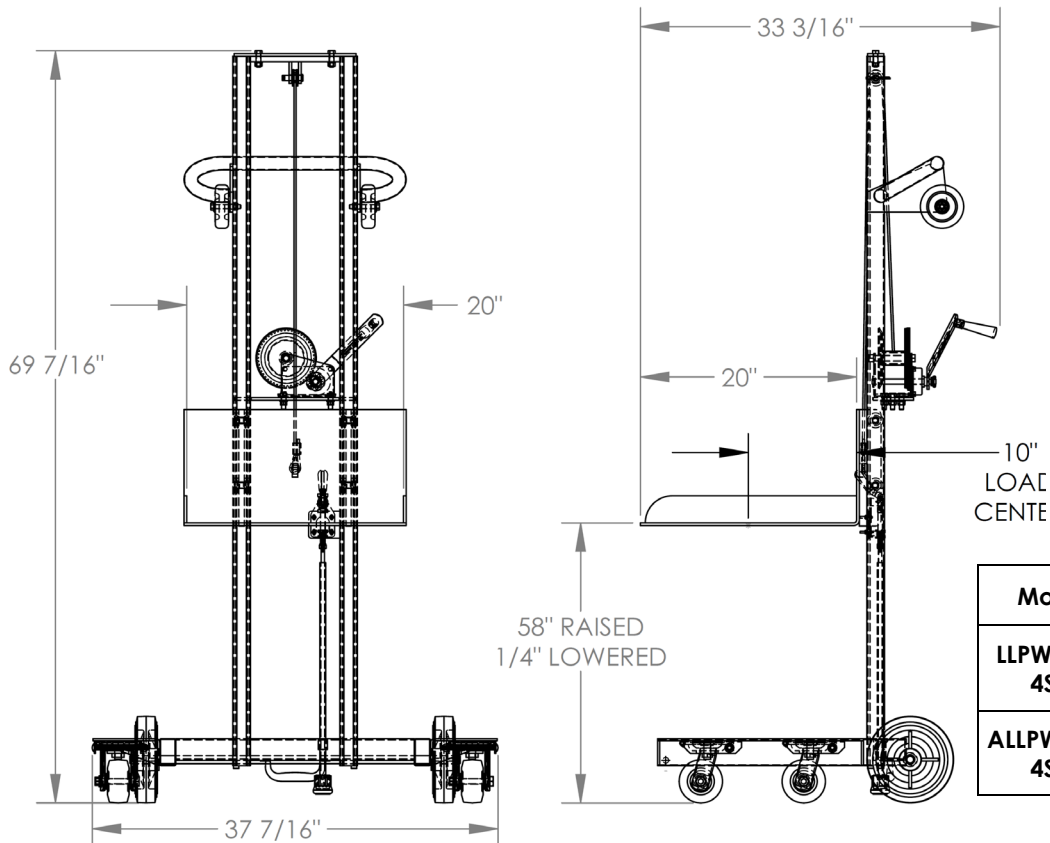

LLPW-4SFL & ALLPW-4SFL



Model	Net weight	Capacity
LLPW-500-4SFL	238 LB. 108.2 KG	400 LB. 181.8 KG
ALLPW-500-4SLF	134 LB. 60.9 KG	400 LB. 181.8 KG

SIGNAL WORDS

SIGNAL WORDS appear in this manual to draw the reader's attention to important safety-related messages. The following are signal words used in this manual and their definitions.

 DANGER	Identifies a hazardous situation which, if not avoided, WILL result in DEATH or SERIOUS INJURY . Use of this signal word is limited to the most extreme situations.
 WARNING	Identifies a hazardous situation which, if not avoided, COULD result in DEATH or SERIOUS INJURY .
 CAUTION	Indicates a hazardous situation which, if not avoided, COULD result in MINOR or MODERATE injury.
NOTICE	Identifies practices likely to result in product/property damage, such as operation that might damage the product.

SAFETY INSTRUCTIONS

Vestil strives to identify foreseeable hazards associated with the use of its products, but no manual can address every conceivable risk. Minimize the likelihood of injury by observing the hazards identified below and by inspecting and maintaining the product as instructed in [INSPECTIONS & MAINTNENANCE](#) on p. 20.

WARNING

Risks of serious personal injuries or death. Always apply material handling techniques learned during training and use the product properly.

- **Read and understand the entire manual before assembling, using or servicing the product.**
- Inspect the lifter as directed in the [INSPECTIONS & MAINTNENANCE](#) instructions on [p. 20](#). DO NOT use the lifter unless it is in satisfactory condition. See [RECORD OF SATISFACTORY CONDITION](#), [p. 19](#).
- ALWAYS inspect the area where the lifter will be used before using it.
- Regardless of whether the lifter is loaded or unloaded, DO NOT stand or travel under the deck.
- Instruct others to stay clear of the device and the supported load during operation.
- Avoid contact with moving parts. In particular, avoid contact with the cable, deck, wheels & rollers.
- DO NOT allow people to ride on the lifter.
- Failure to properly position a load on the deck might result in injury:
 1. DO NOT exceed the maximum rated load (capacity). The rated load appears on label 287 as shown in [LABELING DIAGRAM](#) on p. 21. Also see applicable [SPECIFICATIONS](#) on [p. 2](#) or [3](#).
 2. Center & evenly distribute loads. DO NOT handle off-center loads or loads that cannot be centered.
 3. Start & stop gradually to avoid upsetting the load on the deck. Strap loads to the deck if they might roll or slide.
 4. NEVER tilt the lifter while carrying a load. All wheels and casters must maintain contact with the ground when a load is on the deck.
- ALWAYS observe the deck while raising and lowering it. The deck should rise smoothly and evenly from side-to-side. Watch for binding or jerky movement and listen for unusual noises. Tag the unit "Out of order" and do not use it if you observe anything abnormal.
- Only use this lifter on even, level ground. DO NOT transport loads over inclines or stairs.
- Enlist a coworker to help you lift, load, and unload the unit whenever necessary.
- DO NOT perform maintenance on this product UNLESS it is unloaded and the deck is lowered. If the unit requires repairs, ONLY install manufacturer-approved replacement parts.
- Before leaving the unit unattended, unload it and lower the deck.
- DO NOT use the lifter UNLESS all labels are in place and readable. See [LABELING DIAGRAM](#) on [p. 21](#).
- DO NOT modify this product in any way. Modifying the lifter automatically voids the limited warranty and might make it unsafe to use.

NATIONAL STANDARDS

This product is a manually propelled high lift truck. The Industrial Truck Standards Development Foundation (ITSDF) publishes national standard ANSI/ITSDF B56.10 (the "Standard") on its website (www.itsdf.org). The standard is freely downloadable at <http://www.itsdf.org/cue/b56-standards.html>. Before putting the unit into service, acquire a copy of the Standard and apply all recommendations in Part II: For the User. If instructions provided in this manual conflict with instructions in the Standard, then you should apply the instructions in the Standard. Vestil encourages you to immediately contact [TECHNICAL SERVICE](#) to report any differences between instructions in this manual and the Standard.

**LLW-202058-FW
EXPLODED VIEW & BILL OF MATERIALS
21-006-005**

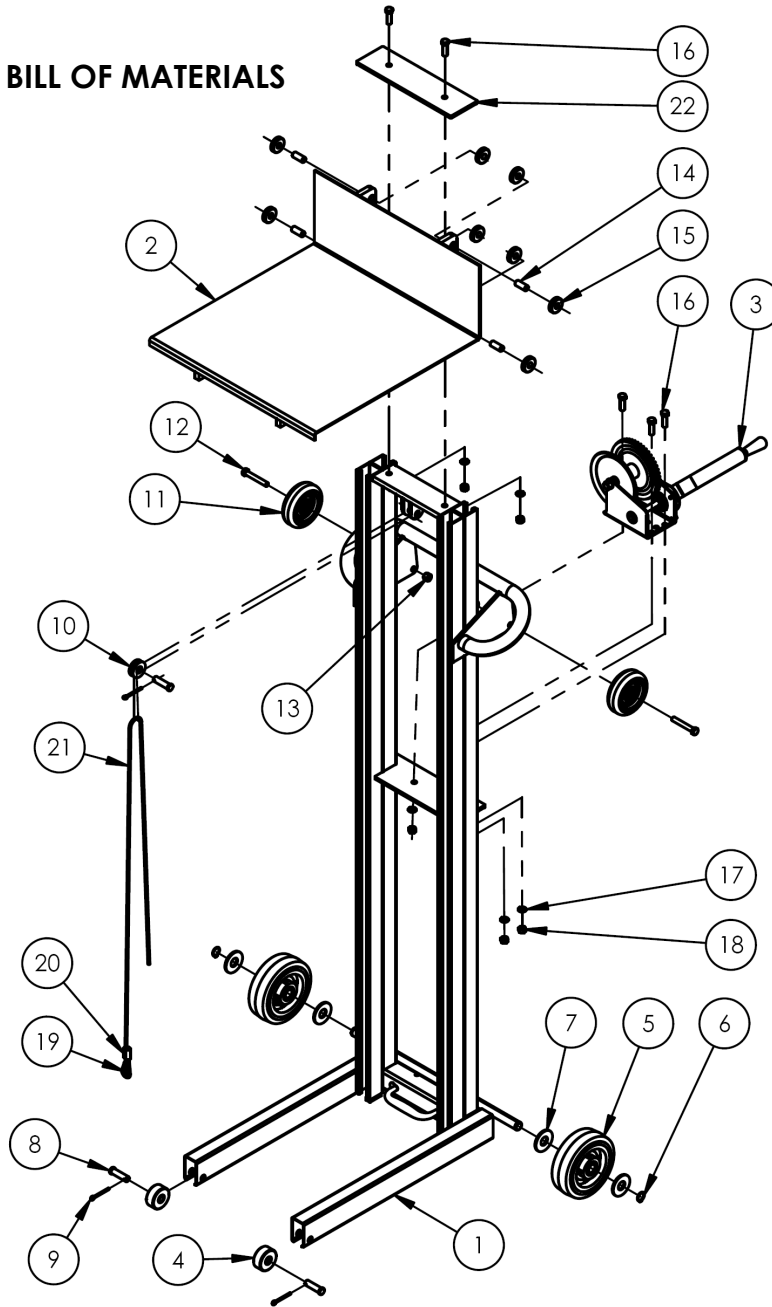

Item	Part no.	Description	Qty.	Item	Part no.	Description	Qty.
1	21-514-005	WELDMENT, FRAME	1	12	11113	HEX BOLT, GRADE A, PLAIN FINISH, 3/8"-16 X 2-1/2"	2
2	21-513-002	WELDMENT, DECK	1	13	37024	NYLON INSERT LOCK NUT, GRADE 2, ZINC FINISH, 3/8"-16	2
3	21-042-002-001	HAND WINCH, ONE PIECE STRAIGHT HANDLE GRIP	1	14	21-112-002	PIN, ROLLER	4
4	21-527-002	SUB-ASSEMBLY, ROLLER W/ BUSHING	2	15	21-027-003	ROLLER, GUIDE	8
5	16-132-058	WHEEL, POLY ON POLY	2	16	11107	HEX BOLT, GRADE A, ZINC FINISH, 3/8"-16 x 1-1/4"	5
6	68015	EXTERNAL RETAINING RING, PHOSPHATE, 3/4"	2	17	33622	SPLIT LOCK WASHER, CARBON STEEL, MEDIUM ZINC FINISH, 3/8"	5
7	33018	USS FLAT WASHER, Z PLATED, Ø 3/4"	4	18	36106	HEX NUT, GRADE A, ZINC PLATED, 3/8-16	5
8	21-112-003	PIN, Ø1/2 X 1-15/16 LG RETAINING CLEVIS	3	19	21-145-013	SPECIALTY HARDWARE, THIMBLE	1
9	65107	COTTER PIN, ZINC FINISH, Ø5/32" X 2"	3	20	99-145-067	COMPRESSION SLEEVE Ø3/16" X 1" LG	1
10	21-527-001	SUB-ASSEMBLY, PULLEY W/BUSHING	1	21	21-145-014	SPECIALTY HARDWARE, Ø3/16" AIR CRAFT CABLE	1
11	16-132-009	PP-4/1.25-W	2	22	21-017-155	BAR, RETAINER	1

**ALLW-2020-FW
EXPLODED VIEW & BILL OF MATERIALS
42-006-004**

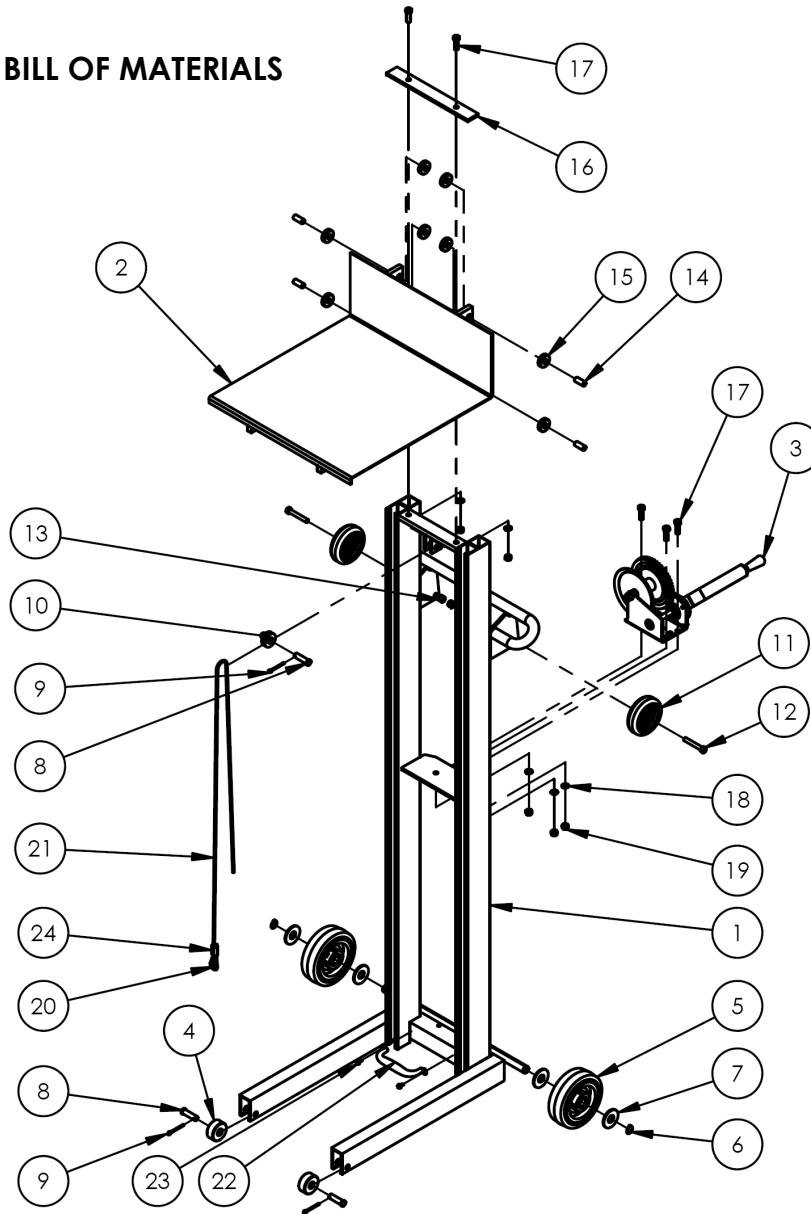

Item	Part no.	Description	Qty.	Item	Part no.	Description	Qty.
1	42-514-008	WELDMENT, FRAME	1	13	37024	NYLON INSERT LOCK NUT, GRADE 2, ZINC FINISH, 3/8"-16	2
2	42-513-006	WELDMENT, DECK	1	14	21-112-002	PIN. ROLLER	4
3	21-042-002-001	HAND WINCH, ONE PIECE STRAIGHT HANDLE GRIP	1	15	42-027-005	ROLLER, GUIDE ROLLER	8
4	21-527-002	SUB-ASSEMBLY, ROLLER W/ BUSHING	2	16	21-017-087	STIFFENER, BAR	1
5	16-132-058	WHEEL, POLY ON POLY	2	17	11107	HEX BOLT, GRADE A, ZINC FINISH, 3/8"-16 x 1-1/4"	5
6	68015	EXTERNAL RETAINING RING, PHOSPHATE, 3/4"	2	18	33622	SPLIT LOCK WASHER, CARBON STEEL, MEDIUM ZINC FINISH, 3/8"	5
7	33018	USS FLAT WASHER, Z PLATED, Ø 3/4"	4	19	36106	HEX NUT, GRADE A, ZINC PLATED, 3/8-16	5
8	21-112-003	PIN, Ø1/2 X 1-15/16 LG RETAINING CLEVIS	3	20	21-145-013	SPECIALTY HARDWARE, THIMBLE	1
9	65107	COTTER PIN, ZINC FINISH, Ø5/32" X 2"	3	21	21-145-014	SPECIALTY HARDWARE, Ø3/16" AIR CRAFT CABLE	1
10	21-527-001	SUB-ASSEMBLY, PULLEY W/BUSHING	1	22	13-025-004-002	HANDLE, WITH HOLES	1
11	16-132-009	PP-4/1.25-W	2	23	31802	SCREW, SELF-TAPPING SCREW	2
12	11113	HEX BOLT, GRADE A, PLAIN FINISH, 3/8"-16 X 2-1/2"	2	24	99-145-067	COMPRESSION SLEEVE Ø3/16" X 1" LG	1

**ALLW-2020-FWFL
EXPLODED VIEW & BILL OF MATERIALS
42-006-028**

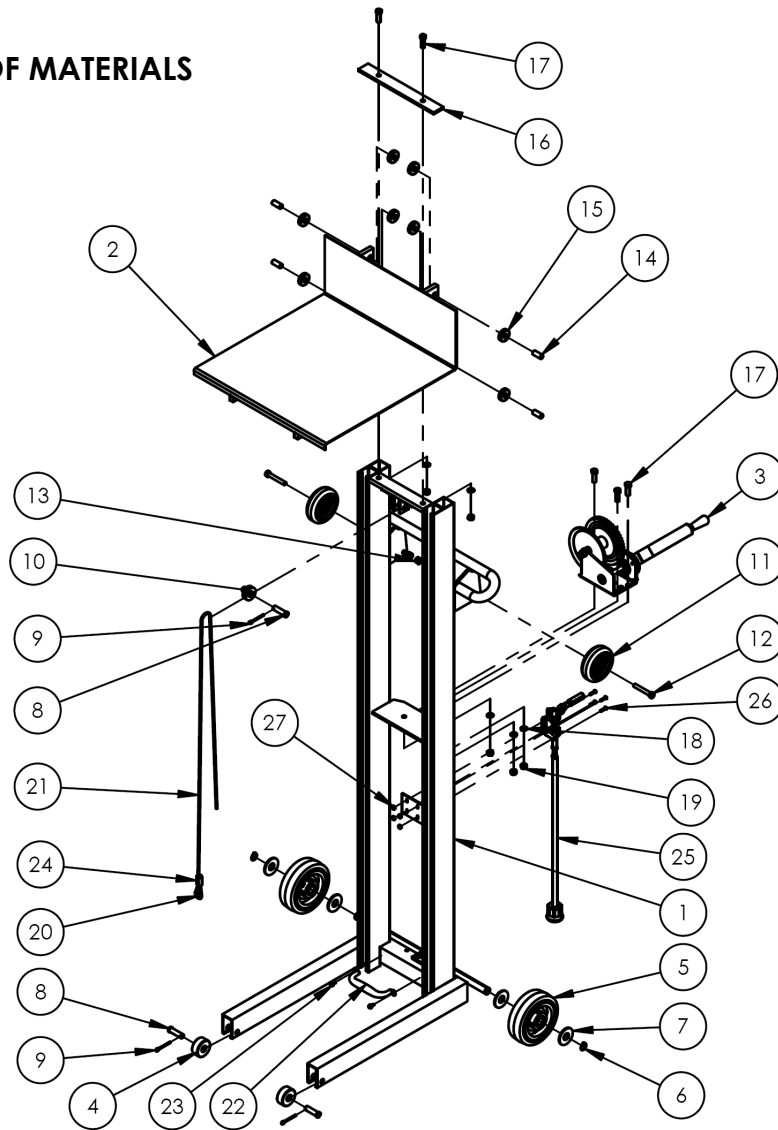

Item	Part no.	Description	Qty.	Item	Part no.	Description	Qty.
1	42-514-034	WELDMENT, FRAME	1	15	42-027-005	ROLLER, GUIDE ROLLER	8
2	42-513-006	WELDMENT, DECK	1	16	21-017-087	STIFFENER, BAR	1
3	21-042-002-001	HAND WINCH, ONE PIECE STRAIGHT HANDLE GRIP	1	17	11107	HEX BOLT, GRADE A, ZINC FINISH, 3/8"-16 x 1-1/4"	5
4	21-527-002	SUB-ASSEMBLY, ROLLER W/ BUSHING	2	18	33622	SPLIT LOCK WASHER, CARBON STEEL, MEDIUM ZINC FINISH, 3/8"	5
5	16-132-058	WHEEL, POLY ON POLY	2	19	36106	HEX NUT, GRADE A, ZINC PLATED, 3/8-16	5
6	68015	EXTERNAL RETAINING RING,PHOSPHATE, 3/4"	2	20	21-145-013	SPECIALTY HARDWARE, THIMBLE	1
7	33018	USS FLAT WASHER, Z PLATED, Ø 3/4"	4	21	21-145-014	SPECIALTY HARDWARE, Ø3/16" AIR CRAFT CABLE	1
8	21-112-003	PIN, Ø1/2 X 1-15/16 LG RETAINING CLEVIS	3	22	13-025-004-002	HANDLE, WITH HOLES	1
9	65107	COTTER PIN, ZINC FINISH, Ø5/32" X 2"	3	23	31802	SCREW, SELF-TAPPING SCREW	2
10	21-527-001	SUB-ASSEMBLY, PULLEY W/BUSHING	1	24	99-145-067	COMPRESSION SLEEVE Ø3/16" X 1" LG	1
11	16-132-009	PP-4/1.25-W	2	25	21-001-132	FINAL ASSEMBLY W/O SHIPPING	1
12	11113	HEX BOLT, GRADE A, PLAIN FINISH, 3/8"-16 X 2-1/2"	2	26	27560	#10-32 x 3/4 LG SLOTTED MACHINE SCREW	4
13	37024	NYLON INSERT LOCK NUT, GRADE 2, ZINC FINISH, 3/8"-16	2	27	37015	10-32 NYLOCK NUT Z-PLATED	4
14	21-112-002	PIN. ROLLER	4				

**LLW-202058-FWFL
EXPLODED VIEW & BILL OF MATERIALS
21-006-157**

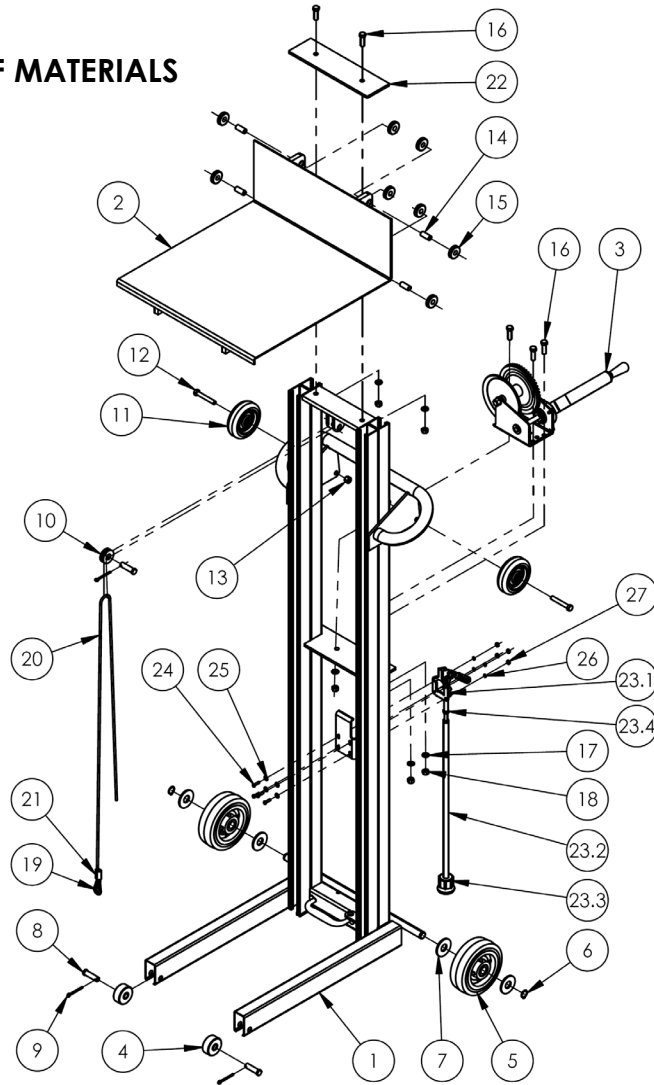

Item	Part no.	Description	Qty.	Item	Part no.	Description	Qty.
1	21-514-171	WELDMENT, FRAME	1	17	33622	SPLIT LOCK WASHER, CARBON STEEL, MEDIUM ZINC FINISH, 3/8"	5
2	21-513-002	WELDMENT, DECK	1	18	36106	HEX NUT, GRADE A, ZINC PLATED, 3/8-16	5
3	21-042-002-001	HAND WINCH, ONE PIECE STRAIGHT HANDLE GRIP	1	19	21-145-013	SPECIALTY HARDWARE, THIMBLE	1
4	21-527-002	SUB-ASSEMBLY, ROLLER W/ BUSHING	2	20	21-145-014	SPECIALTY HARDWARE, Ø3/16" AIR CRAFT CABLE	1
5	16-132-058	WHEEL, POLY ON POLY	2	21	99-145-067	COMPRESSION SLEEVE Ø3/16" X 1" LG	1
6	68015	EXTERNAL RETAINING RING, PHOSPHATE, 3/4"	2	22	21-017-155	BAR, RETAINER	1
7	33018	USS FLAT WASHER, Z PLATED, Ø 3/4"	4	23	21-001-132	FINAL ASSEMBLY W/O SHIPPING	1
8	21-112-003	PIN, Ø1/2 X 1-15/16 LG RETAINING CLEVIS	3	23.1	21-145-001	SPECIALTY HARDWARE, PUSH-PULL CLAMP	1
9	65107	COTTER PIN, ZINC FINISH, Ø5/32" X 2"	3	23.2	21-537-006	WELDMENT, FLOOR LOCK	1
10	21-527-001	SUB-ASSEMBLY, PULLEY W/BUSHING	1	23.3	14-037-005	RUBBER STOP CRUTCH TIP	1
11	16-132-009	PP-4/1.25-W	2	23.4	40307	HEX NUT, CLASS 8, ZINC PLATED, M8-1.25	1
12	11113	HEX BOLT, GRADE A, PLAIN FINISH, 3/8"-16 X 2-1/2"	2	24	27560	#10-32 x 3/4 LG SLOTTED MACHINE SCREW	4
13	37024	NYLON INSERT LOCK NUT, GRADE 2, ZINC FINISH, 3/8"-16	2	25	33074	SAE FLAT WASHER, Z-PLATED, 3/16" (#10)	4
14	21-112-002	PIN, ROLLER	4	26	33614	LOCK WASHER, Z-PLATED, #10	4
15	21-027-003	ROLLER, GUIDE	8	27	36030	10-32 HEX NUT	4
16	11107	HEX BOLT, GRADE A, ZINC FINISH, 3/8"-16 x 1-1/4"	5				

**LLW-202058-FWWL
EXPLODED VIEW & BILL OF MATERIALS
21-006-162**

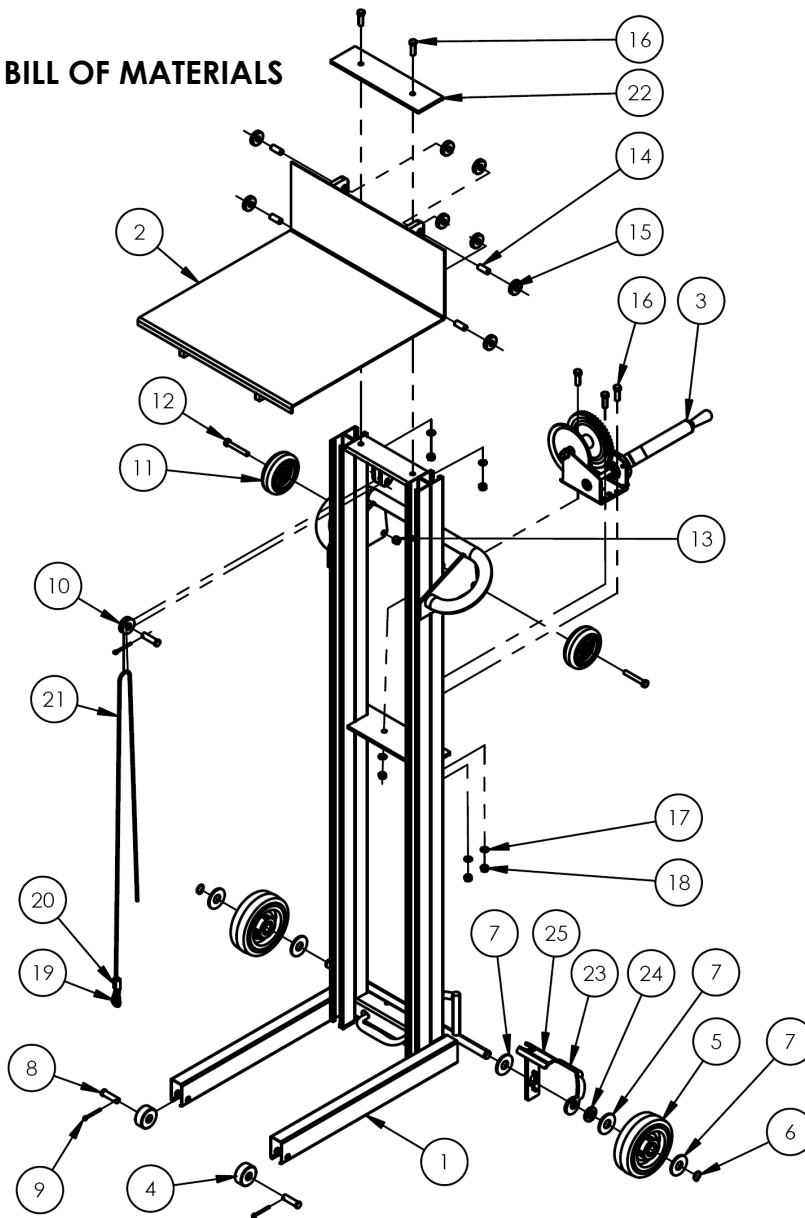

Item	Part no.	Description	Qty.	Item	Part no.	Description	Qty.
1	21-514-175	WELDMENT, FRAME	1	14	21-112-002	PIN, ROLLER	4
2	21-513-002	WELDMENT, DECK	1	15	21-027-003	ROLLER, GUIDE	8
3	21-042-002-001	HAND WINCH, ONE PIECE STRAIGHT HANDLE GRIP	1	16	11107	HEX BOLT, GRADE A, ZINC FINISH, 3/8"-16 x 1-1/4"	5
4	21-527-002	SUB-ASSEMBLY, ROLLER W/ BUSHING	2	17	33622	SPLIT LOCK WASHER, CARBON STEEL, MEDIUM ZINC FINISH, 3/8"	5
5	16-132-058	WHEEL, POLY ON POLY	2	18	36106	HEX NUT, GRADE A, ZINC PLATED, 3/8-16	5
6	68015	EXTERNAL RETAINING RING,PHOSPHATE, 3/4"	2	19	21-145-013	SPECIALTY HARDWARE, THIMBLE	1
7	33018	USS FLAT WASHER, Z PLATED, Ø 3/4"	5	20	99-145-067	COMPRESSION SLEEVE Ø3/16" X 1" LG	1
8	21-112-003	PIN, Ø1/2 X 1-15/16 LG RETAINING CLEVIS	3	21	21-145-014	SPECIALTY HARDWARE, Ø3/16" AIR CRAFT CABLE	1
9	65107	COTTER PIN, ZINC FINISH, Ø5/32" X 2"	3	22	21-017-155	BAR, RETAINER	1
10	21-527-001	SUB-ASSEMBLY, PULLEY W/BUSHING	1	23	21-037-015	LOCK, BRAKE LEVER	1
11	16-132-009	PP-4/1.25-W	2	24	21-014-227	FRAME, FLAT WASHER	1
12	11113	HEX BOLT, GRADE A, PLAIN FINISH, 3/8"-16 X 2-1/2"	2	25	21-537-010	WELDMENT, WHEEL BRAKE	1
13	37024	NYLON INSERT LOCK NUT, GRADE 2, ZINC FINISH, 3/8"-16	2				

LLW-242060-4SFL
EXPLODED VIEW & BILL OF MATERIALS
21-006-007

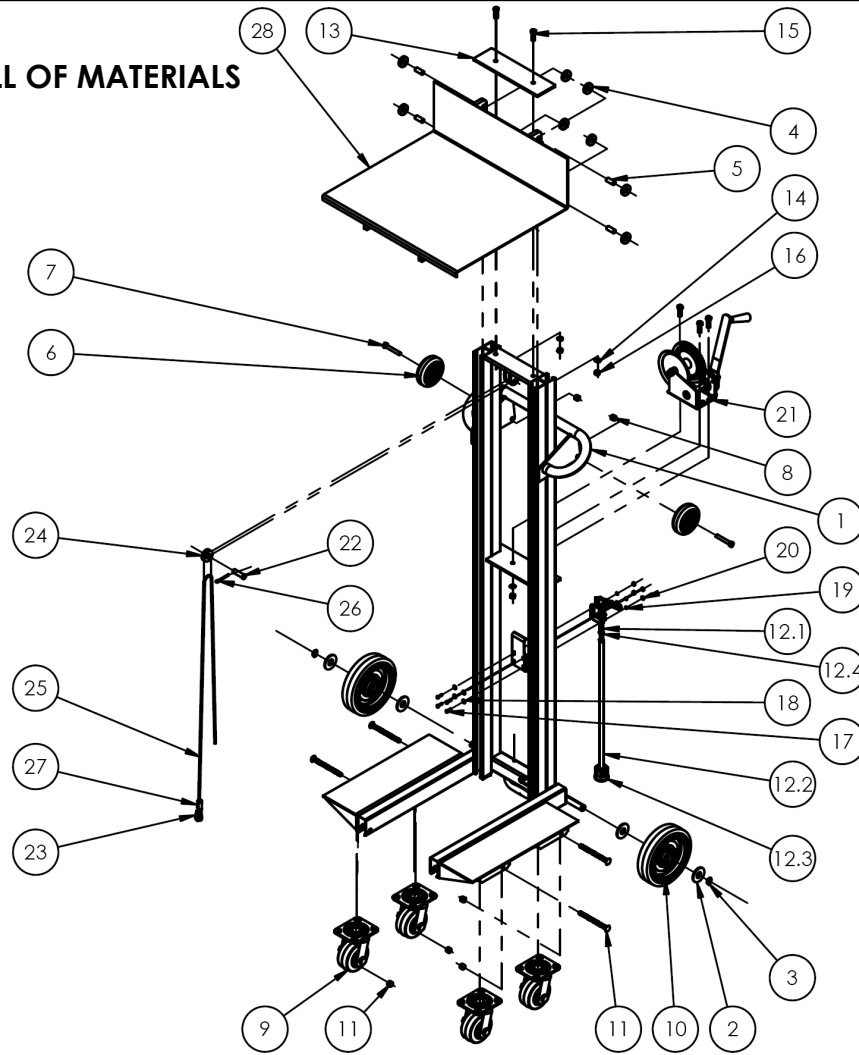

Item	Part no.	Description	Qty.	Item	Part no.	Description	Qty.
1	21-514-007	WELDMENT, FRAME	1	13	21-017-155	BAR, RETAINER	1
2	33018	USS FLAT WASHER, Z PLATED, Ø 3/4"	4	14	33622	SPLIT LOCK WASHER, CARBON STEEL, MEDIUM ZINC FINISH, 3/8"	5
3	68015	EXTERNAL RETAINING RING,PHOSPHATE, 3/4"	2	15	11107	HEX BOLT, GRADE A, ZINC FINISH, 3/8"-16 x 1-1/4"	5
4	21-027-003	ROLLER, GUIDE	8	16	36106	HEX NUT, GRADE A, ZINC PLATED, 3/8-16	5
5	21-112-002	PIN, ROLLER	4	17	27560	#10-32 x 3/4 LG SLOTTED MACHINE SCREW	4
6	16-132-009	PP-4/1.25-W	2	18	33074	SAE FLAT WASHER, Z-PLATED, 3/16" (#10)	4
7	11113	HEX BOLT, GRADE A, PLAIN FINISH, 3/8"-16 X 2-1/2"	2	19	33614	LOCK WASHER, Z-PLATED, #10	4
8	37024	NYLON INSERT LOCK NUT, GRADE 2, ZINC FINISH, 3/8"-16	2	20	36030	10-32 HEX NUT	4
9	16-132-011	CASTER SWIVEL, 4X2	4	21	21-042-002-001	HAND WINCH, ONE PIECE STRAIGHT HANDLE GRIP	1
10	16-132-200	CASTER, PP-8/2-W, RED	2	22	21-112-003	PIN, Ø1/2 X 1-15/16 LG RETAINING CLEVIS	1
11	99-612-001	PIN, BULLDOG BOLT AND NUT ASSEMBLY	4	23	21-145-013	SPECIALTY HARDWARE, THIMBLE	1
12	21-001-132	FINAL ASSEMBLY W/O SHIPPING	1	24	21-527-001	SUB-ASSEMBLY, PULLEY W/BUSHING	1
12.1	21-145-001	SPECIALTY HARDWARE, PUSH-PULL CLAMP	1	25	21-145-014	SPECIALTY HARDWARE, Ø3/16" AIR CRAFT CABLE	1
12.2	21-537-006	WELDMENT, FLOOR LOCK	1	26	65107	COTTER PIN, ZINC FINISH, Ø5/32" X 2"	1
12.3	14-037-005	RUBBER STOP CRUTCH TIP	1	27	99-145-067	COMPRESSION SLEEVE Ø3/16" X 1" LG	1
12.4	40307	HEX NUT, CLASS 8, ZINC PLATED, M8-1.25	1	28	21-513-003	WELDMENT, DECK	1

ALLW-2420-4SFL
EXPLODED VIEW & BILL OF MATERIALS
42-006-019

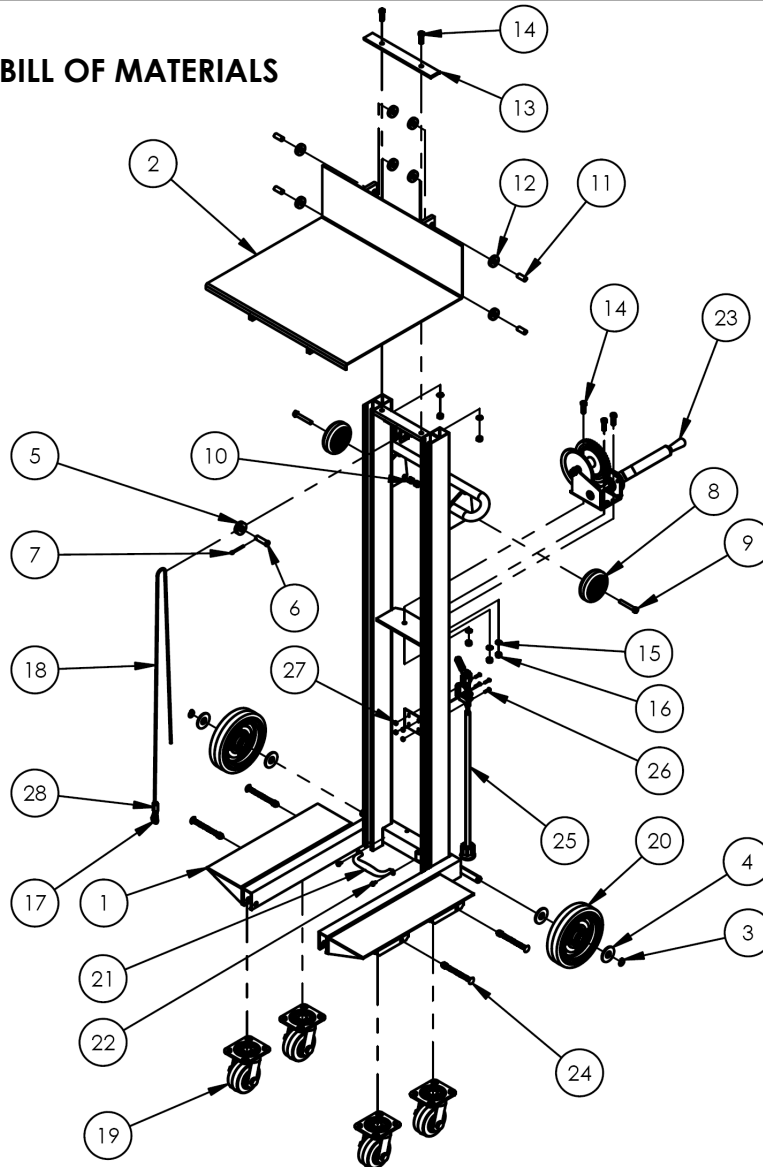

Item	Part no.	Description	Qty.	Item	Part no.	Description	Qty.
1	42-514-014	WELDMENT, FRAME	1	15	33622	SPLIT LOCK WASHER, CARBON STEEL, MEDIUM ZINC FINISH, 3/8"	5
2	42-513-007	WELDMENT, DECK	1	16	36106	HEX NUT, GRADE A, ZINC PLATED, 3/8-16	5
3	68015	EXTERNAL RETAINING RING,PHOSPHATE, 3/4"	2	17	21-145-013	SPECIALTY HARDWARE, THIMBLE	1
4	33018	USS FLAT WASHER, Z PLATED, Ø 3/4"	4	18	21-145-014	SPECIALTY HARDWARE, Ø3/16" AIR CRAFT CABLE	1
5	21-527-001	SUB-ASSEMBLY, PULLEY W/BUSHING	1	19	16-132-011	CASTER SWIVEL, 4X2	4
6	21-112-003	PIN, Ø1/2 X 1-15/16 LG RETAINING CLEVIS	1	20	16-132-200	CASTER, PP-8/2-W, RED	2
7	65107	COTTER PIN, ZINC FINISH, Ø5/32" X 2"	1	21	13-025-004-002	HANDLE, WITH HOLES	1
8	16-132-009	PP-4/1.25-W	2	22	31802	SCREW, SELF-TAPPING SCREW	2
9	11113	HEX BOLT, GRADE A, PLAIN FINISH, 3/8"-16 X 2-1/2"	2	23	21-042-002-001	HAND WINCH, ONE PIECE STRAIGHT HANDLE GRIP	1
10	37024	NYLON INSERT LOCK NUT, GRADE 2, ZINC FINISH, 3/8"-16	2	24	99-612-001	PIN, BULLDOG BOLT AND NUT ASSEMBLY	4
11	21-112-002	PIN. ROLLER	4	25	21-001-132	FINAL ASSEMBLY W/O SHIPPING	1
12	42-027-005	ROLLER, GUIDE ROLLER	8	26	27560	#10-32 x 3/4 LG SLOTTED MACHINE SCREW	4
13	21-017-087	STIFFENER, BAR	1	27	37015	10-32 NYLOCK NUT Z-PLATED	4
14	11107	HEX BOLT, GRADE A, ZINC FINISH, 3/8"-16 x 1-1/4"	5	28	99-145-067	COMPRESSION SLEEVE Ø3/16" X 1" LG	1

**LLPW-500-FW
EXPLODED VIEW & BILL OF MATERIALS
42-006-011**

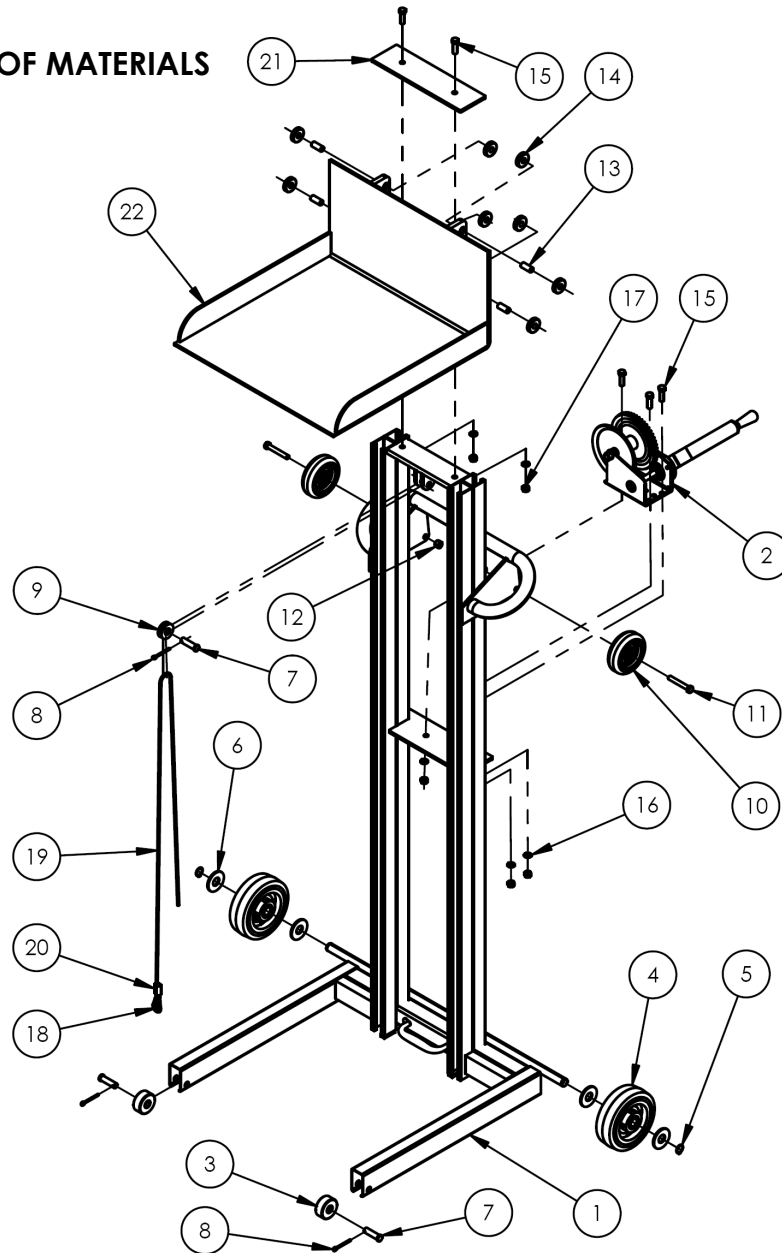

Item	Part no.	Description	Qty.	Item	Part no.	Description	Qty.
1	33-514-056	WELDMENT, FRAME	1	12	37024	NYLON INSERT LOCK NUT, GRADE 2, ZINC FINISH, 3/8"-16	2
2	21-042-002-001	HAND WINCH, ONE PIECE STRAIGHT HANDLE GRIP	1	13	21-112-002	PIN. ROLLER	4
3	21-527-002	SUB-ASSEMBLY, ROLLER W/ BUSHING	2	14	21-027-003	ROLLER, GUIDE	8
4	16-132-058	WHEEL, POLY ON POLY	2	15	11107	HEX BOLT, GRADE A, ZINC FINISH, 3/8"-16 x 1-1/4"	5
5	68015	EXTERNAL RETAINING RING, PHOSPHATE, 3/4"	2	16	33622	SPLIT LOCK WASHER, CARBON STEEL, MEDIUM ZINC FINISH, 3/8"	5
6	33018	USS FLAT WASHER, Z PLATED, Ø 3/4"	4	17	36106	HEX NUT, GRADE A, ZINC PLATED, 3/8-16	5
7	21-112-003	PIN, Ø1/2 X 1-15/16 LG RETAINING CLEVIS	3	18	21-145-013	SPECIALTY HARDWARE, THIMBLE	1
8	65107	COTTER PIN, ZINC FINISH, Ø5/32" X 2"	3	19	21-145-014	SPECIALTY HARDWARE, Ø3/16" AIR CRAFT CABLE	1
9	21-527-001	SUB-ASSEMBLY, PULLEY W/BUSHING	1	20	99-145-067	COMPRESSION SLEEVE Ø3/16" X 1" LG	1
10	16-132-009	PP-4/1.25-W	2	21	21-017-155	BAR, RETAINER	1
11	11113	HEX BOLT, GRADE A, PLAIN FINISH, 3/8"-16 X 2-1/2"	2	22	33-513-032	WELDMENT, DECK	1

**LLPW-500-FWFL
EXPLODED VIEW & BILL OF MATERIALS
21-006-159**

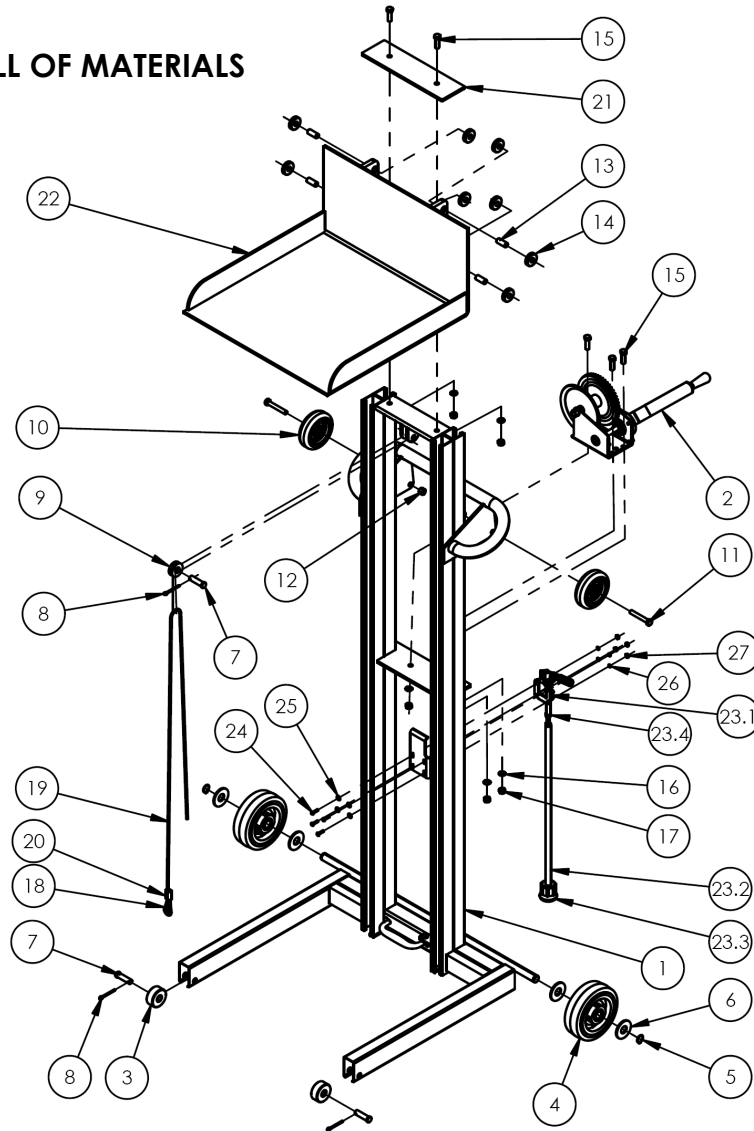

Item	Part no.	Description	Qty.	Item	Part no.	Description	Qty.
1	21-514-173	WELDMENT, FRAME	1	17	36106	HEX NUT, GRADE A, ZINC PLATED, 3/8-16	5
2	21-042-002-001	HAND WINCH, ONE PIECE STRAIGHT HANDLE GRIP	1	18	21-145-013	SPECIALTY HARDWARE, THIMBLE	1
3	21-527-002	SUB-ASSEMBLY, ROLLER W/ BUSHING	2	19	21-145-014	SPECIALTY HARDWARE, Ø3/16" AIR CRAFT CABLE	1
4	16-132-058	WHEEL, POLY ON POLY	2	20	99-145-067	COMPRESSION SLEEVE Ø3/16" X 1" LG	1
5	68015	EXTERNAL RETAINING RING,PHOSPHATE, 3/4"	2	21	21-017-155	BAR, RETAINER	1
6	33018	USS FLAT WASHER, Z PLATED, Ø 3/4"	4	22	33-513-032	WELDMENT, DECK	1
7	21-112-003	PIN, Ø1/2 X 1-15/16 LG RETAINING CLEVIS	3	23	21-001-132	FINAL ASSEMBLY W/O SHIPPING	1
8	65107	COTTER PIN, ZINC FINISH, Ø5/32" X 2"	3	23.1	21-145-001	SPECIALTY HARDWARE, PUSH-PULL CLAMP	1
9	21-527-001	SUB-ASSEMBLY, PULLEY W/BUSHING	1	23.2	21-537-006	WELDMENT, FLOOR LOCK	1
10	16-132-009	PP-4/1.25-W	2	23.3	14-037-005	RUBBER STOP CRUTCH TIP	1
11	11113	HEX BOLT, GRADE A, PLAIN FINISH, 3/8"-16 X 2-1/2"	2	23.4	40307	HEX NUT, CLASS 8, ZINC PLATED, M8-1.25	1
12	37024	NYLON INSERT LOCK NUT, GRADE 2, ZINC FINISH, 3/8"-16	2	24	27560	#10-32 x 3/4 LG SLOTTED MACHINE SCREW	4
13	21-112-002	PIN, ROLLER	4	25	33074	SAE FLAT WASHER, Z-PLATED, 3/16" (#10)	4
14	21-027-003	ROLLER, GUIDE	8	26	33614	LOCK WASHER, Z-PLATED, #10	4
15	11107	HEX BOLT, GRADE A, ZINC FINISH, 3/8"-16 x 1-1/4"	5	27	36030	10-32 HEX NUT	4
16	33622	SPLIT LOCK WASHER, CARBON STEEL, MEDIUM ZINC FINISH, 3/8"	5				

**ALLPW-500-FW
EXPLODED VIEW & BILL OF MATERIALS
42-006-015**

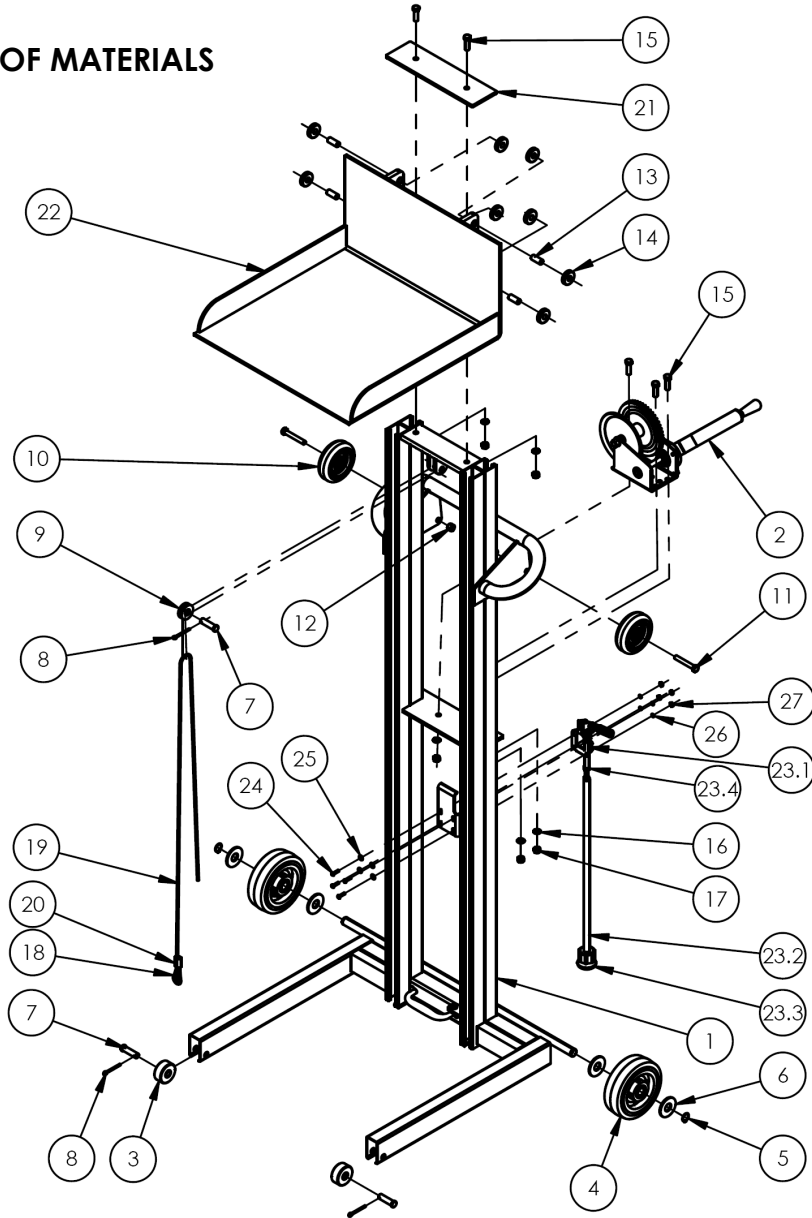

Item	Part no.	Description	Qty.	Item	Part no.	Description	Qty.
1	42-514-016	WELDMENT, FRAME	1	13	21-042-002-001	HAND WINCH, ONE PIECE STRAIGHT HANDLE GRIP	1
2	21-513-038	WELDMENT, DECK	1	14	11107	HEX BOLT, GRADE A, ZINC FINISH, 3/8"-16 x 1-1/4"	5
3	16-132-058	WHEEL, POLY ON POLY	2	15	33622	SPLIT LOCK WASHER, CARBON STEEL, MEDIUM ZINC FINISH, 3/8"	5
4	33018	USS FLAT WASHER, Z PLATED, Ø 3/4"	4	16	36106	HEX NUT, GRADE A, ZINC PLATED, 3/8-16	5
5	68015	EXTERNAL RETAINING RING, PHOSPHATE, 3/4"	2	17	21-017-087	STIFFENER, BAR	1
6	21-112-003	PIN, Ø1/2 X 1-15/16 LG RETAINING CLEVIS	3	18	21-527-001	SUB-ASSEMBLY, PULLEY W/BUSHING	1
7	65107	COTTER PIN, ZINC FINISH, Ø5/32" X 2"	3	19	21-145-014	SPECIALTY HARDWARE, Ø3/16" AIR CRAFT CABLE	1
8	42-027-005	ROLLER, GUIDE ROLLER	8	20	21-145-013	SPECIALTY HARDWARE, THIMBLE	1
9	21-112-002	PIN, ROLLER	4	21	13-025-004-002	HANDLE, WITH HOLES	1
10	16-132-009	PP-4/1.25-W	2	22	31802	SCREW, SELF-TAPPING SCREW	2
11	11113	HEX BOLT, GRADE A, PLAIN FINISH, 3/8"-16 X 2-1/2"	2	23	21-527-002	SUB-ASSEMBLY, ROLLER W/ BUSHING	2
12	37024	NYLON INSERT LOCK NUT, GRADE 2, ZINC FINISH, 3/8"-16	2	24	99-145-067	COMPRESSION SLEEVE Ø3/16" X 1" LG	1

**ALLPW-500-FWFL
EXPLODED VIEW & BILL OF MATERIALS
42-006-030**

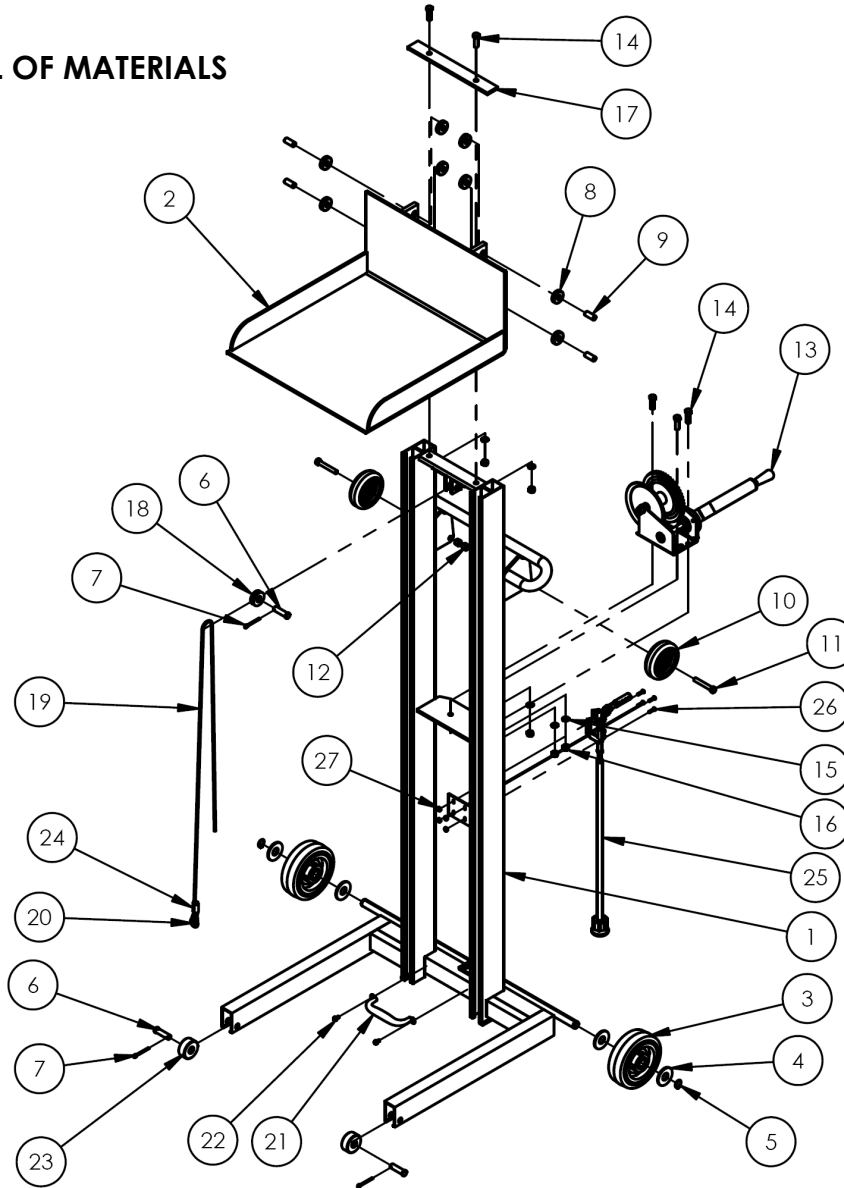

Item	Part no.	Description	Qty.	Item	Part no.	Description	Qty.
1	42-514-036	WELDMENT, FRAME	1	15	33622	SPLIT LOCK WASHER, CARBON STEEL, MEDIUM ZINC FINISH, 3/8"	5
2	21-513-038	WELDMENT, DECK	1	16	36106	HEX NUT, GRADE A, ZINC PLATED, 3/8-16	5
3	16-132-058	WHEEL, POLY ON POLY	2	17	21-017-087	STIFFENER, BAR	1
4	33018	USS FLAT WASHER, Z PLATED, Ø 3/4"	4	18	21-527-001	SUB-ASSEMBLY, PULLEY W/BUSHING	1
5	68015	EXTERNAL RETAINING RING, PHOSPHATE, 3/4"	2	19	21-145-014	SPECIALTY HARDWARE, Ø3/16" AIR CRAFT CABLE	1
6	21-112-003	PIN, Ø1/2 X 1-15/16 LG RETAINING CLEVIS	3	20	21-145-013	SPECIALTY HARDWARE, THIMBLE	1
7	65107	COTTER PIN, ZINC FINISH, Ø5/32" X 2"	3	21	13-025-004-002	HANDLE, WITH HOLES	1
8	42-027-005	ROLLER, GUIDE ROLLER	8	22	31802	SCREW, SELF-TAPPING SCREW	2
9	21-112-002	PIN, ROLLER	4	23	21-527-002	SUB-ASSEMBLY, ROLLER W/ BUSHING	2
10	16-132-009	PP-4/1.25-W	2	24	99-145-067	COMPRESSION SLEEVE Ø3/16" X 1" LG	1
11	11113	HEX BOLT, GRADE A, PLAIN FINISH, 3/8"-16 X 2-1/2"	2	25	21-001-132	FINAL ASSEMBLY W/O SHIPPING	1
12	37024	NYLON INSERT LOCK NUT, GRADE 2, ZINC FINISH, 3/8"-16	2	26	27560	#10-32 x 3/4 LG SLOTTED MACHINE SCREW	4
13	21-042-002-001	HAND WINCH, ONE PIECE STRAIGHT HANDLE GRIP	1	27	37015	10-32 NYLOCK NUT Z-PLATED	4
14	11107	HEX BOLT, GRADE A, ZINC FINISH, 3/8"-16 x 1-1/4"	5				

LLPW-500-4SFL
Exploded View & Bill of Materials
42-006-001

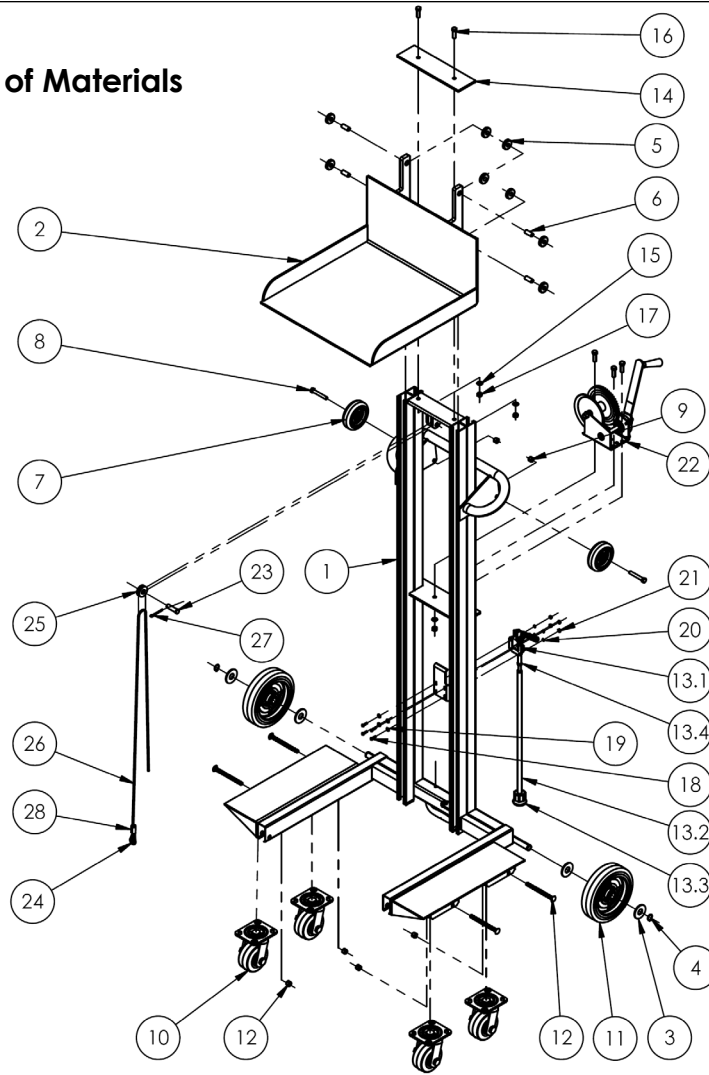

Item	Part no.	Description	Qty.	Item	Part no.	Description	Qty.
1	42-514-006	WELDMENT, FRAME	1	13.4	40307	HEX NUT, CLASS 8, ZINC PLATED, M8-1.25	1
2	33-513-093	WELDMENT, DECK	1	14	21-017-155	BAR, RETAINER	1
3	33018	USS FLAT WASHER, Z PLATED, Ø 3/4"	4	15	33622	SPLIT LOCK WASHER, CARBON STEEL, MEDIUM ZINC FINISH, 3/8"	5
4	68015	EXTERNAL RETAINING RING,PHOSPHATE, 3/4"	2	16	11107	HEX BOLT, GRADE A, ZINC FINISH, 3/8"-16 x 1-1/4"	5
5	21-027-003	ROLLER, GUIDE	8	17	36106	HEX NUT, GRADE A, ZINC PLATED, 3/8-16	5
6	21-112-002	PIN. ROLLER	4	18	27560	#10-32 x 3/4 LG SLOTTED MACHINE SCREW	4
7	16-132-009	PP-4/1.25-W	2	19	33074	SAE FLAT WASHER, Z-PLATED, 3/16" (#10)	4
8	11113	HEX BOLT, GRADE A, PLAIN FINISH, 3/8"-16 X 2-1/2"	2	20	33614	LOCK WASHER, Z-PLATED, #10	4
9	37024	NYLON INSERT LOCK NUT, GRADE 2, ZINC FINISH, 3/8"-16	2	21	36030	10-32 HEX NUT	4
10	16-132-011	CASTER SWIVEL, 4X2	4	22	21-042-002-001	HAND WINCH, ONE PIECE STRAIGHT HANDLE GRIP	1
11	16-132-200	CASTER, PP-8/2-W, RED	2	23	21-112-003	PIN, Ø1/2 X 1-15/16 LG RETAINING CLEVIS	1
12	99-612-001	PIN, BULLDOG BOLT AND NUT ASSEMBLY	4	24	21-145-013	SPECIALTY HARDWARE, THIMBLE	1
13	21-001-132	FINAL ASSEMBLY W/O SHIPPING	1	25	21-527-001	SUB-ASSEMBLY, PULLEY W/BUSHING	1
13.1	21-145-001	SPECIALTY HARDWARE, PUSH-PULL CLAMP	1	26	21-145-014	SPECIALTY HARDWARE, Ø3/16" AIR CRAFT CABLE	1
13.2	21-537-006	WELDMENT, FLOOR LOCK	1	27	65107	COTTER PIN, ZINC FINISH, Ø5/32" X 2"	1
13.3	14-037-005	RUBBER STOP CRUTCH TIP	1	28	99-145-067	COMPRESSION SLEEVE Ø3/16" X 1" LG	1

ALLPW-500-4SFL
EXPLODED VIEW & BILL OF MATERIALS
21-006-061

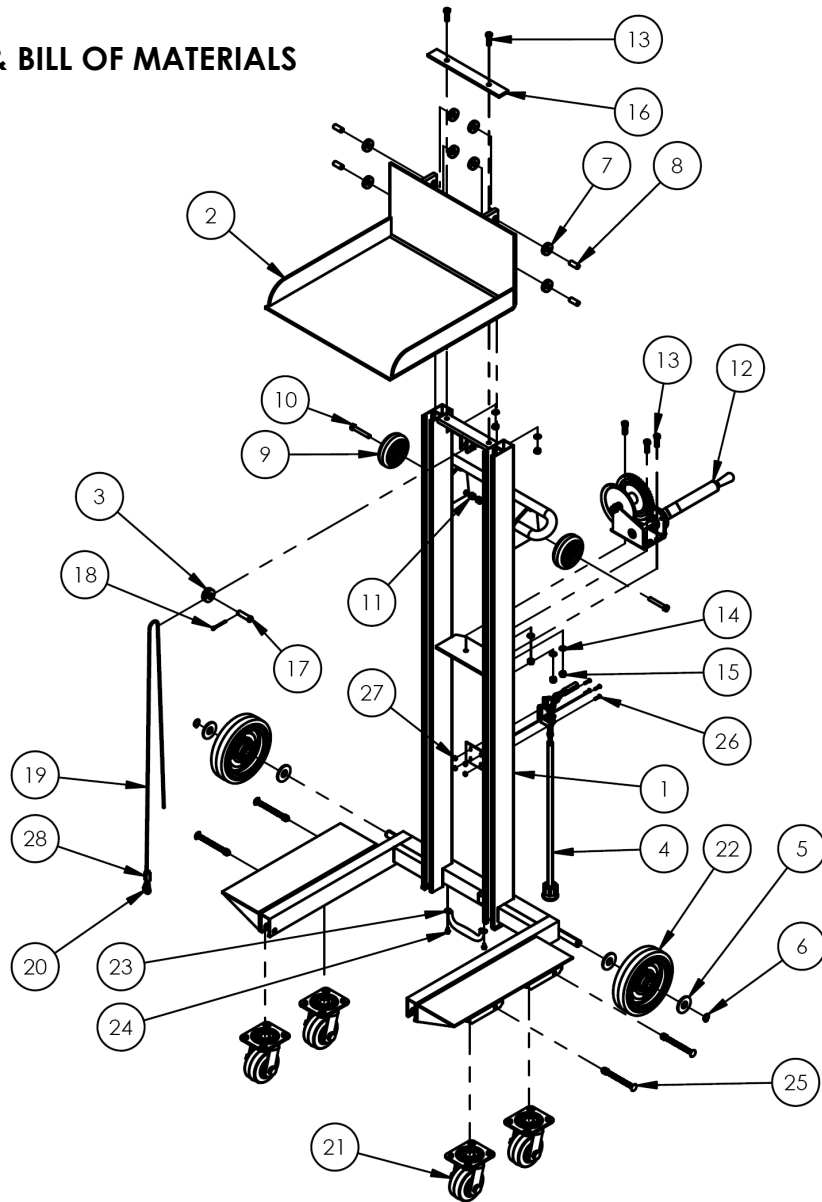

Item	Part no.	Description	Qty.	Item	Part no.	Description	Qty.
1	21-513-038	WELDMENT, DECK	1	15	36106	HEX NUT, GRADE A, ZINC PLATED, 3/8-16	5
2	21-527-001	SUB-ASSEMBLY, PULLEY W/BUSHING	1	16	21-017-087	STIFFENER, BAR	1
3	21-001-132	FINAL ASSEMBLY W/O SHIPPING	1	17	21-112-003	PIN, Ø1/2 X 1-15/16 LG RETAINING CLEVIS	1
4	33018	USS FLAT WASHER, Z PLATED, Ø 3/4"	4	18	65107	COTTER PIN, ZINC FINISH, Ø5/32" X 2"	1
5	68015	EXTERNAL RETAINING RING, PHOSPHATE, 3/4"	2	19	21-145-014	SPECIALTY HARDWARE, Ø3/16" AIR CRAFT CABLE	1
6	42-027-005	ROLLER, GUIDE ROLLER	8	20	21-145-013	SPECIALTY HARDWARE, THIMBLE	1
7	21-112-002	PIN, ROLLER	4	21	16-132-011	CASTER SWIVEL, 4X2	4
8	16-132-009	PP-4/1.25-W	2	22	16-132-200	CASTER, PP-8/2-W, RED	2
9	11113	HEX BOLT, GRADE A, PLAIN FINISH, 3/8"-16 X 2-1/2"	2	23	13-025-004-002	HANDLE, WITH HOLES	1
10	37024	NYLON INSERT LOCK NUT, GRADE 2, ZINC FINISH, 3/8"-16	2	24	31802	SCREW, SELF-TAPPING SCREW	2
11	21-042-002-001	HAND WINCH, ONE PIECE STRAIGHT HANDLE GRIP	1	25	99-612-001	PIN, BULLDOG BOLT AND NUT ASSEMBLY	4
12	11107	HEX BOLT, GRADE A, ZINC FINISH, 3/8"-16 X 1-1/4"	5	26	27560	#10-32 x 3/4 LG SLOTTED MACHINE SCREW	4
13	33622	SPLIT LOCK WASHER, CARBON STEEL, MEDIUM ZINC FINISH, 3/8"	5	27	37015	10-32 NYLOCK NUT Z-PLATED	4
14	21-513-038	WELDMENT, DECK	1	28	99-145-067	COMPRESSION SLEEVE Ø3/16" X 1" LG	1

RAISING AND LOWERING THE DECK

To raise and lower the deck, the lifter is equipped with a manual winch.

Winch: To raise the platform, rotate the handle clockwise. The platform rises ~1 inch with each rotation. To lower the platform, rotate the handle counterclockwise. Lay the handle on the winch mounting bracket as shown when the deck is elevated.

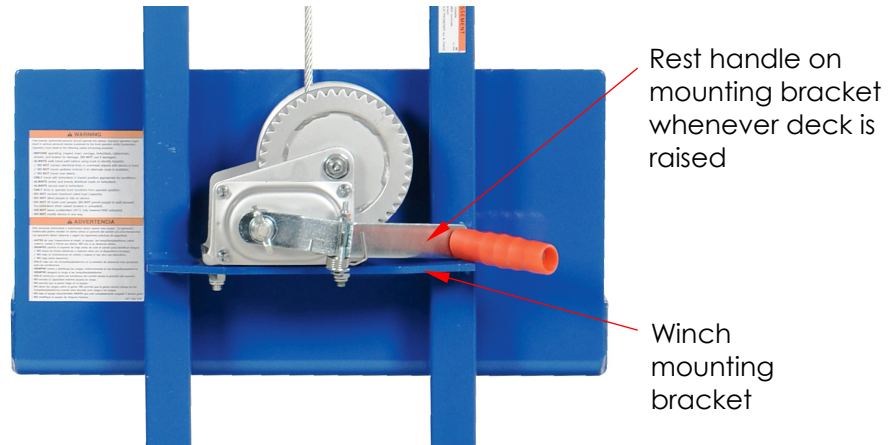

USING THE HAND TRUCK

This product is a “manually-propelled high lift industrial truck” according to the national standard ANSI/ITSDF B56.10-2012 (“B56.10”). Acquire a copy of B56.10, which is available at no cost through the ITSDf website (www.itsdf.org), and review the operation recommendations. Instructions in this manual are meant to **supplement** those recommendations.

ONLY use this device after completing the training program outlined in B56.10, sections 4.17 and 4.18.1-4.

- Develop safe working habits and an awareness of hazardous conditions occurring or present during operation of the lifter.
- Inspect the area where the lifter will be used **before each use** to identify unusual operating conditions. Implement additional safety precautions as conditions require. Conditions might include:
 1. Irregularities in the floor/surface;
 2. Debris or other obstructions on the floor/surface;
 3. Unsound surfaces, i.e. surfaces that cannot support your weight plus the weight of the lifter and a full capacity load.
- Perform the following **function test before each use**:
 1. Raise and lower the deck and confirm normal operating condition of the lift mechanisms.
 2. Test the casters/wheels: wheels should roll smoothly, should not be severely worn, and should be rigidly fastened to the frame of the lifter.

Inspect the lifter as recommended in the **INSPECTIONS & MAINTENANCE** section of this manual on [page 20](#). Use the lifter only if it is in normal operating condition.

Step 1: Grasp the handle with both hands. Walk behind the lifter and keep your feet away from the wheels.

Step 2: Move the lifter to a position near the load. If the lifter is equipped with either a floor lock engage the device to prevent the lifter from moving.

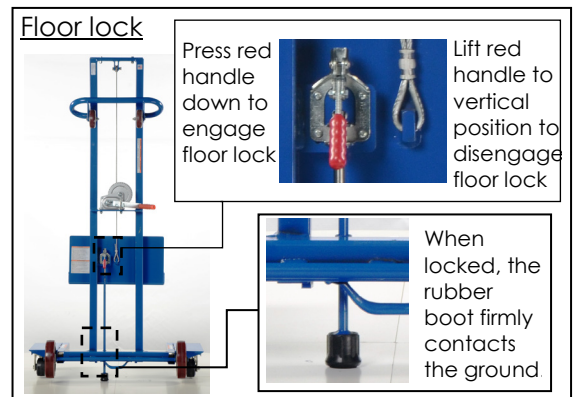
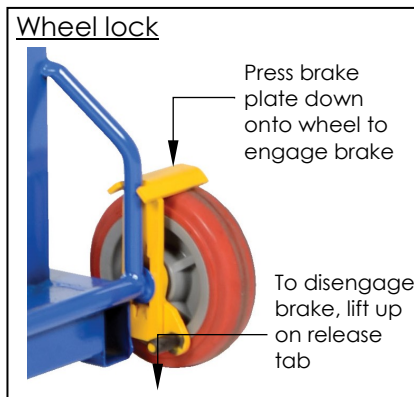

Step 3: Raise the deck to bring it to the level of the load. Turn the handle clockwise to elevate the deck. Turn the handle counterclockwise to lower the deck.

Step 4: Center the load on the deck. Secure it to the deck (with ratchet straps, for example) if necessary to prevent the load from sliding, rolling, etc.

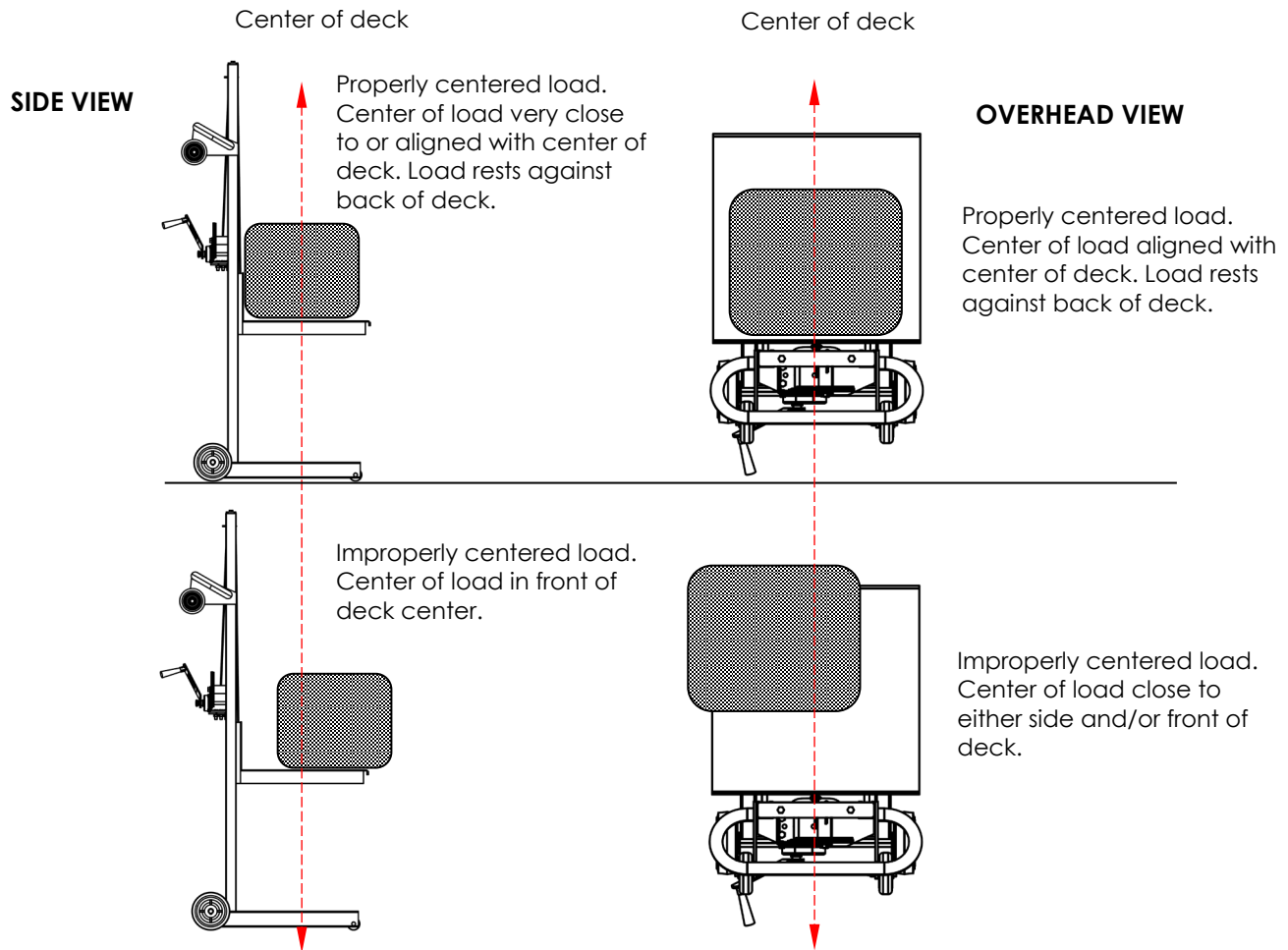

Step 5: Lower the deck until it is just a few inches above the ground. Move the load to the desired location. After you arrive at the unloading destination:

- Lock the castors or set the brakes;
- Turn the handle clockwise until the load is positioned at a comfortable height;
- Rest the handle on the winch mounting bracket; and
- Remove the load.

Step 6: Lower the deck until it is a few inches above the legs and return the lifter to its storage location. Engage the brakes (if equipped with optional brakes) and lower the deck completely. Store the lifter in a dry, indoor location.

RECORD OF SATISFACTORY CONDITION (THE “RECORD”)

Record the condition of the hand truck before putting it into service. Thoroughly photograph the unit from multiple angles so that all operating mechanisms are clearly visible. Take close range photographs of the labeling applied to the truck. Raise and lower the deck. Describe the operation of the winch. Describe sounds heard as the deck rises and descends. How much effort is required to turn the winch? Apply the brake and/or floor lock (if equipped). Photograph the brake and/or lock. Try to move the truck with the brake applied and describe how the brake resists movement. Collect all photographs and writings in a single file. Give the file a name that clearly identifies it. This file is a record of the unit in satisfactory condition. Compare the findings of all inspections to the record to determine whether the truck is in satisfactory condition. Purely cosmetic changes, like damaged paint/powder coat are not changes from satisfactory condition. However, touch-up paint to be applied to all affected areas as soon as damage occurs.

INSPECTIONS & MAINTENANCE

Regular inspections and maintenance are necessary to keep the device in normal condition. Compare the results of each inspection to the [RECORD](#) to determine whether the unit is satisfactory condition or requires repairs or replacement parts. If you are uncertain whether a part requires repair or replacement, contact [TECHNICAL SERVICE](#) for assistance.

- Periodically lubricate moving parts.
- Keep the product clean and dry.
- Only use manufacturer- approved replacement parts.

At least once every 2 weeks, inspect the following components:

1. Winch, winch mounting bracket (see [RAISING AND LOWERING THE DECK](#) on p. 18), cable, and pulley: Cycle the deck up and down. Listen for unusual noises and watch for binding or rough movement as the deck moves. Examine the winch. Make sure that the spool is intact and rotates smoothly when the handle is turned. Inspect the mounting bracket. The winch should be solidly attached to the bracket. Tighten all loose fasteners. Lower the deck and examine the cable for reeving, stretching, thinning portions, etc. Confirm that the pulley rotates freely and is securely fastened to the mast.
2. Frame (mast, base, deck, and deck rollers): examine the frame members for damaged welds, severe rusting, cracks, bends, etc. Remove rust with steel wool. Clean the affected areas and apply touch-up paint.
3. Casters and wheels: check each caster and wheel for wobbling, damage, and severe wear. Wheels and casters should roll smoothly. Clean the casters to remove grit from the surfaces, if necessary.
4. Hardware: examine the pins, bolts, nuts, etc. Tighten loose fasteners.
5. Floor lock: if your unit is equipped with the floor lock option confirm that it makes solid contact with the ground when applied. Check the condition of the rubber pad. Replace the pad if wear or damage affects its function.

Maintenance: Implement a maintenance program to ensure that the lifter functions properly. Page 9 of ANSI/ITSDF standard B56.10-2006, "Manually propelled high lift industrial trucks", describes recommended maintenance procedures. A copy of the standard is downloadable for free from the ITSDF website (see www.itsdf.org). Apply those recommendations in conjunction with the following steps.

1. Tag the lifter, "Out of Service."
2. Inspect the lifter as described above. If deformity, corrosion, rusting, or excessive wear of structural members is present, DO NOT use the lifter. If the deck does not move smoothly or makes noise as it moves up or down the upright, apply a silicon wax or silicon spray to the inside of the mast frame.
3. Remove any dirt or other matter from the cable and pulleys and other lifter surfaces.
4. Perform all other necessary adjustments and/or repairs. DO NOT modify the lifter.
5. Make a dated record of the repairs, adjustments and/or replacements made.
6. Platform, mast and platform rollers: cycle the platform up and down while listening for unusual noises and watching for binding or rough movement.

LABELING DIAGRAM

The unit should be labeled as shown in the diagram. However, label content and location are subject to change so your product might not be labeled exactly as shown. Thoroughly photograph the unit when you first receive it as discussed in the [RECORD OF SATISFACTORY CONDITION](#) section of this manual. Make sure that your Record includes a photograph of each label. Modify this diagram, if necessary, to indicate labeling actually applied. Replace all labels that are, damaged, missing, or not easily readable (e.g. faded). Contact the [TECHNICAL SERVICE & REPLACEMENT PARTS DEPARTMENT](#) online at http://www.vestilmfg.com/parts_info.htm to order replacement labels. You may also call (260) 665-7586 and ask the operator to connect you to the [REPLACEMENT PARTS DEPARTMENT](#).

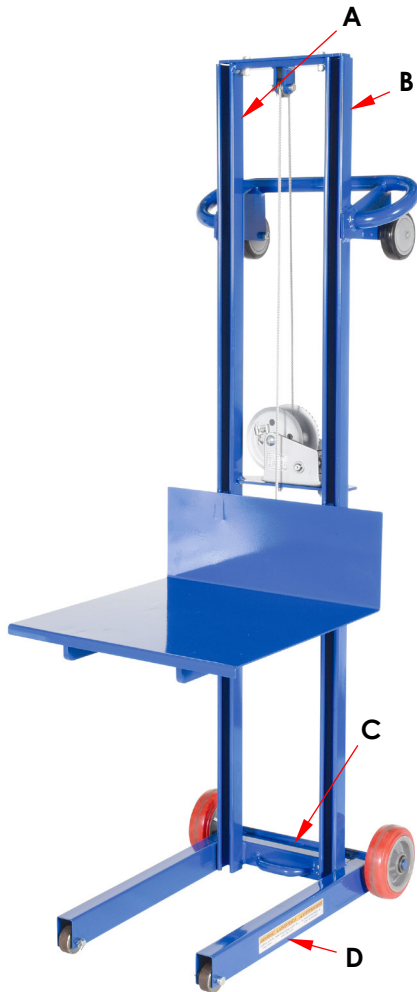

A: Label 1153 (on back side of mast)

MODEL / MODÉLO / MODÈLE	_____
WEIGHT / PESO / MASS	_____
CAPACITY / CAPACIDAD / CAPACITÉ	_____
SERIAL / SERIE / SÉRIE	_____
UNITS: 2.2 lb. = 1kg	1" (or 1in.) = 2.54cm
	1153

B: Label 527 (on back side of mast)

⚠ WARNING
<p>Only trained, authorized persons should operate this device. Improper operation might result in serious personal injuries sustained by the truck operator and/or bystanders. Operators must observe the following safety-enhancing practices:</p> <ul style="list-style-type: none"> • BEFORE operating, inspect mast, carriage, forks/deck, cable/chain, wheels, and brakes for damage. DO NOT use if damaged. • ALWAYS walk travel path before using truck to identify hazards: <ul style="list-style-type: none"> 3 DO NOT contact electrical lines or overhead objects with device or load; 3 DO NOT travel up/down inclines if an alternate route is available; 3 DO NOT travel over debris. • ONLY travel with forks/deck in lowest position appropriate for conditions. • ALWAYS center and evenly distribute loads on forks/deck. • ALWAYS secure load to forks/deck. • ONLY drive or operate truck functions from operator position. • DO NOT exceed maximum rated load (capacity). • DO NOT allow people to ride on device. • DO NOT lift loads over people; DO NOT permit people to walk beneath the forks/deck when raised (loaded or unloaded). • DO NOT leave unattended UNTIL fully lowered AND unloaded. • DO NOT modify device in any way.
⚠ ADVERTENCIA
<p>Solo personas entrenadas y autorizadas deben operar este equipo. La operación inadecuada podría resultar en daños serios al operario del camión y/o a los transeuntes. Los operarios deben observar y seguir las siguientes prácticas de seguridad:</p> <ul style="list-style-type: none"> • ANTES de usar, inspeccione el mástil, el equipo, las horquillas/plataforma/cadena, ruedas y frenos por daños. NO use si se observan daños. • SIEMPRE camine el trayecto de viaje antes de usar el camión para identificar riesgos: <ul style="list-style-type: none"> 3 NO toque las líneas eléctricas u objetos altos con el dispositivo o la carga; 3 NO viaje en inclinaciones de subida y bajada si hay otra ruta alternativa; 3 NO viaje sobre desechos. • SOLO viaje con las horquillas/plataforma en la posición de descenso más apropiada para las condiciones. • SIEMPRE centre y distribuya las cargas uniformemente en las horquillas/plataforma. • SIEMPRE asegure la carga a las horquillas/plataforma. • SOLO conduzca u opere las funciones del camión desde la posición del operario. • NO exceda la capacidad máxima tasada de carga. • NO permita que la gente viaje en el equipo. • NO eleve las cargas sobre la gente; NO permita que la gente camine debajo de las horquillas/plataforma cuando este elevada (con carga o sin carga). • NO deje el equipo desatendido HASTA que este completamente cargado Y descargado. • NO modifique el equipo de ninguna manera. <p style="text-align: right; font-size: small;">527 - Rev 1109</p>

C: Label 212 (on cross member of models with floor lock and/or caster brake)

⚠ WARNING	⚠ ADVERTENCIA	⚠ AVERTISSEMENT
Immobilize by applying all caster brakes and/or floor locks when in use, loading, and unloading.	Inmovilice aplicando todos los frenos de las ruedas y / o bloqueos del piso cuando esté en uso, cargando y descargando.	Immobiliser en appliquant tous les freins des roulettes et / ou les verrous de plancher lors de l'utilisation, du chargement et du déchargement.
		212 Rev 0920

D: Label 208 (on both legs)

⚠ WARNING	⚠ ADVERTENCIA	⚠ AVERTISSEMENT
KEEP CLEAR OF PINCH POINT	MANTENGASE ALEJADO DEL PUNTO DE CORTE	SE TENIR À DISTANCE DU POINT DE PINCEMENT
		208A

LIMITED WARRANTY

Vestil Manufacturing Corporation ("Vestil") warrants this product to be free of defects in material and workmanship during the warranty period. Our warranty obligation is to provide a replacement for a defective, original part covered by the warranty after we receive a proper request from the Warrantee (you) for warranty service.

Who may request service?

Only a warrantee may request service. You are a warrantee if you purchased the product from Vestil or from an authorized distributor AND Vestil has been fully paid.

Definition of "original part"?

An original part is a part used to make the product as shipped to the Warrantee.

What is a "proper request"?

A request for warranty service is proper if Vestil receives: 1) a photocopy of the Customer Invoice that displays the shipping date; AND 2) a written request for warranty service including your name and phone number. Send requests by one of the following methods:

US Mail	Fax	Email
Vestil Manufacturing Corporation 2999 North Wayne Street, PO Box 507 Angola, IN 46703	(260) 665-1339 Phone (260) 665-7586	info@vestil.com Enter "Warranty service request" in subject field.

In the written request, list the parts believed to be defective and include the address where replacements should be delivered. After Vestil receives your request for warranty service, an authorized representative will contact you to determine whether your claim is covered by the warranty. Before providing warranty service, Vestil will require you to send the entire product, or just the defective part (or parts), to its facility in Angola, IN.

What is covered under the warranty?

The warranty covers defects in the following original, dynamic parts: motors, hydraulic pumps, motor controllers, and cylinders. It also covers defects in original parts that wear under normal usage conditions ("wearing parts"), such as bearings, hoses, wheels, seals, brushes, and batteries.

How long is the warranty period?

The warranty period for original dynamic components is 90 days. For wearing parts, the warranty period is 90 days. Both warranty periods begin on the date Vestil ships the product to the Warrantee. If the product was purchased from an authorized distributor, the periods begin when the distributor ships the product. Vestil may, at its sole discretion, extend a warranty period for products shipped from authorized distributors by up to 30 days to account for shipping time.

If a defective part is covered by the warranty, what will Vestil do to correct the problem?

Vestil will provide an appropriate replacement for any covered part. An authorized representative of Vestil will contact you to discuss your claim.

What is not covered by the warranty?

The Warrantee (you) is responsible for paying labor costs and freight costs to return the product to Vestil for warranty service.

Events that automatically void this Limited Warranty.

- Misuse;
- Negligent assembly, installation, operation or repair;
- Installation/use in corrosive environments;
- Inadequate or improper maintenance;
- Damage sustained during shipping;
- Collisions or other accidents that damage the product;
- Unauthorized modifications: Do not modify the product IN ANY WAY without first receiving written authorization from Vestil.

Do any other warranties apply to the product?

Vestil Manufacturing Corp. makes no other express warranties. All implied warranties are disclaimed to the extent allowed by law. Any implied warranty not disclaimed is limited in scope to the terms of this Limited Warranty. Vestil makes no warranty or representation that this product complies with any state or local design, performance, or safety code or standard. Noncompliance with any such code or standard is not a defect in material or workmanship.

